

International Cooperation for Integration of
Processes in Prepress, Press, and Postpress

Addendum to the Specification of the **CIP3TM** Print Production Format

Version 1.0a
November 20, 2000

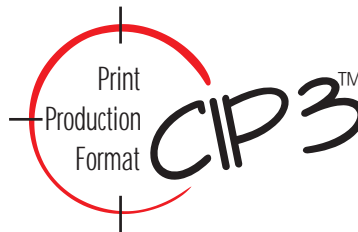

Stefan Daun
Reinhard Koch
Jürgen Schönhut

FRAUNHOFER INSTITUTE FOR COMPUTER GRAPHICS (FRAUNHOFER-IGD)
Department Integrated Publishing and eBusiness Solutions
Rundeturmstrasse 6, 64283 Darmstadt, Germany
Phone: +49 - 6151 -155 220
Fax: +49 - 6151 - 155 299

*Please send any comment on this document to Stefan Daun
Email: Stefan.Daun@igd.fhg.de — Fax: +49 - 6151 - 155 299*

00i014-FIGD

The CIP3 Print Production Format was specified by the Fraunhofer Institute for Computer Graphics in close collaboration with a group of about 40 well-known manufacturers. This group was called "International Cooperation for Integration of Prepress, Press, and Postpress" (abbreviated as CIP3).

The Print Production Format is now implemented by many of the member companies in systems that are working today in hundreds of printing companies around the world. The success of PPF has created demands in two areas. On one side there is the demand for including further technical information into the format (e.g. for web printing). On the other side there is the demand that the production process control should be integrated with information management systems in printing companies.

In particular for the latter reason, CIP3 has decided to widen its scope of activity and to reorganize its structure to provide the appropriate infrastructure. As a result of this reorganization, the group is now called "International Cooperation for Integration of Processes in Prepress, Press, and Postpress" (abbreviated as CIP4).

More information about CIP4, its current members, and the Print Production Format is available from the CIP4 website:

<http://www.cip4.org>

The CIP3 PPF Specification Version 3.0 and this document can be downloaded from the website at the following addresses:

http://www.cip4.org/documents/technical_info/cip3v3_0.pdf

http://www.cip4.org/documents/technical_info/cip3v3_0_addendum.pdf

Content

1	Overview	5
2	Coordinate Systems and Transformations	6
2.1	Introduction	6
2.2	Surface-based Coordinate Systems	8
2.3	Block-based Coordinate Systems	9
2.4	Relation Between Coordinate Systems of Different Surfaces or Print Runs	9
2.5	Coordinate System Used for Folding	13
2.6	Coordinate Systems Used in the Product Definition Section	14
2.7	Example	15
3	Web Printing Extensions	18
3.1	Specification	18
3.1.1	Explanations	18
3.1.2	Web Printing Requirements	19
3.1.3	New Operations	20
3.1.3.1	Dividing	20
3.1.3.2	Gluing	22
3.1.4	New Definitions	23
3.1.4.1	Encoding of Product Definition Hierarchy	23
3.2	Web Printing Examples	26
3.2.1	Example: 16 Pages, Portrait	27
3.2.2	Example: 16 Pages open, Portrait	30
3.2.3	Example: 16 Pages, Landscape	33
3.2.4	Example: 24 Pages, Portrait	37
3.2.5	Example: 2 x 4 Pages Broadsheet, Collected	41
3.2.6	Example: 2 x 4 Pages Broadsheet, Non-collected	45
3.2.7	Example: 36 Pages, Portrait	49
3.3	Glossary	53
3.3.1	General Terms	53
3.3.2	Press Terms	53
3.3.3	Postpress Terms	55
4	Multiple Plates Per Cylinder	57
4.1	Specification	58
4.2	Examples	59
5	New Attributes	64

6	Implementation Guidelines	65
6.1	What should the value of the CIP3AdmJobName key in a PPF file be?	65
6.2	What should the value of the CIP3AdmSheetName key in a PPF file be?	65
6.3	Size of attributes of type String	66
6.4	Do I need to include CIP3AdmPaperExtent etc. in a PPF file?	66
6.5	CIP3 PPF Version Number	66
7	Known Errors in CIP3 PPF Version 3.0	67
Appendix A	Index of Keywords	68

1 Overview

This document is an addendum to version 3.0 of the Specification of the CIP3 Print Production Format, which was published on June 2, 1998. The addendum does not specify a new version of CIP3 PPF. Instead, its goal is to explain how to work with the current specification. Nevertheless, a few definitions (attributes and postpress operations) are added to the specification by this addendum.

Chapter 2 explains the coordinate systems as they are defined in CIP3 PPF Version 3.0. In addition it shows how the transformation matrices are used to transform coordinates from one coordinate system to another.

Chapter 3 describes some extensions to CIP3 PPF for web printing applications. Most of the definitions given here do not specify new CIP3 PPF objects, but instead explain and define how the objects already defined in CIP3 PPF version 3.0 can be used for web printing applications. Nevertheless, a few new items have to be defined, like the *Dividing* and *Gluing* operations.

Chapter 4 explains how to create CIP3 PPF files in a scenario where multiple plates are mounted to one press cylinder. In order to be able to store the information about which plate is mounted where, two new attributes are defined.

In chapter 5, five new attributes (including the two of chapter 4) are introduced, which are added to the CIP3 PPF Specification. Since they all are optional, compatibility with “standard” CIP3 PPF Version 3.0 files is not affected.

Chapter 6 presents some implementation guidelines which are intended as clarifications of some issues arising from the CIP3 Print Production Format (PPF) specification.

Finally, in chapter 7 a list of known errors of the CIP3 PPF Specification Version 3.0 is given together with the corresponding corrections.

2 Coordinate Systems and Transformations

This chapter explains the coordinate systems as they are defined in CIP3 PPF Version 3.0. In addition it shows how the transformation matrices are used to transform coordinates from one coordinate system to another coordinate system.

2.1 Introduction

In prepress the coordinates of many objects (e.g. register marks or cut marks) are stored within a CIP3 PPF file by using the PostScript coordinate system. At later production stages these objects appear on different media (e.g. on film, plate, or paper) each having its own dimensions and its own coordinate system. It is therefore necessary to transform coordinates between the different coordinate systems, which in turn requires the specification of the relation between them. This relation is specified by a transformation matrix.

A convenient way to calculate coordinate transformations in a two-dimensional space is by using so-called *homogeneous coordinates*. With this concept, a coordinate $P=(x,y)$ is expressed in vector form as $[x \ y \ 1]$. The third element "1" is added to allow the vector being multiplied with a transformation matrix describing scaling, rotation, and translation in one shot. Although this only requires a 2*3 matrix (as it is used in PostScript for example), in practice 3*3 matrices are much more common, because they can be concatenated very easily. Thus, the third column is set to "0 0 1".

$$\text{Trf} = \begin{bmatrix} a & b & 0 \\ c & d & 0 \\ e & f & 1 \end{bmatrix} \quad \text{would in PostScript be written as } [a \ b \ c \ d \ e \ f]$$

Example 2-1: Some often used transformation matrices

$$\text{Trf} = \begin{bmatrix} 1 & 0 & 0 \\ 0 & 1 & 0 \\ 0 & 0 & 1 \end{bmatrix} \quad \text{identity transformation}$$

$$\text{Trf} = \begin{bmatrix} 1 & 0 & 0 \\ 0 & 1 & 0 \\ dx & dy & 1 \end{bmatrix} \quad \text{translation by } dx, dy$$

$$\text{Trf} = \begin{bmatrix} \cos\varphi & \sin\varphi & 0 \\ -\sin\varphi & \cos\varphi & 0 \\ 0 & 0 & 1 \end{bmatrix} \quad \text{rotation by } \varphi \text{ degrees counter-clockwise}$$

Example 2-2: Transforming a point

In this example, the position P1 given in the film coordinate system is transformed to a position of the plate coordinate system. The relation between the two coordinate systems is given by the transformation matrix $\text{Trf}_{\text{Plate}}$.

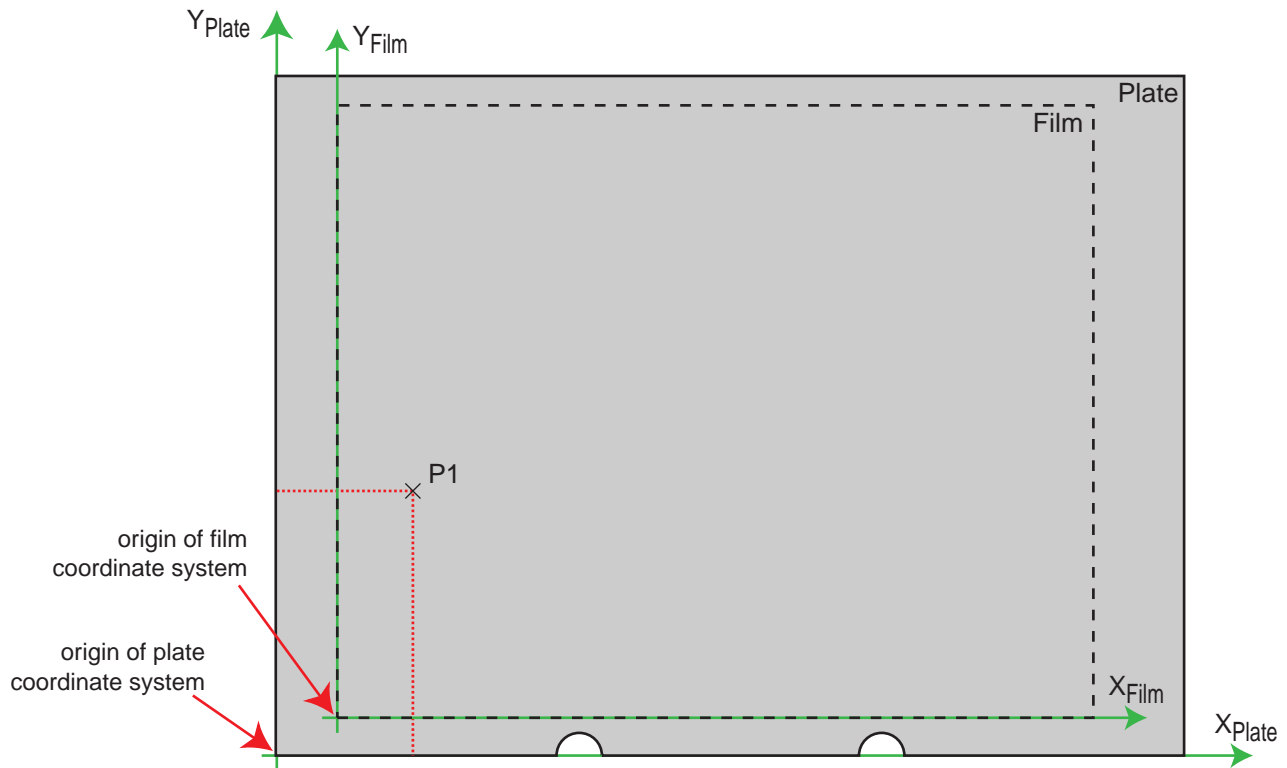

Illustration 2-1: Plate coordinate system and film coordinate system

$$P1_{\text{Film}} = [10 \ 30 \ 1]$$

$$P1_{\text{Film}} = (10, 30)$$

$$P1_{\text{Plate}} = P1_{\text{Film}} \times \text{Trf}_{\text{Plate}}$$

$$P1_{\text{Plate}} = [10 \ 30 \ 1] \times \begin{bmatrix} 1 & 0 & 0 \\ 0 & 1 & 0 \\ 8 & 5 & 1 \end{bmatrix}$$

in PostScript, $\text{Trf}_{\text{Plate}}$ is written as $[1 \ 0 \ 0 \ 1 \ 8 \ 5]$

$$P1_{\text{Plate}} = [18 \ 35 \ 1]$$

$$P1_{\text{Plate}} = (18, 35)$$

2.2 Surface-based Coordinate Systems

Each of the coordinate systems used in CIP3 PPF is — with one exception (the PostScript coordinate system) — strongly bound to a physical object.



The origin of the PostScript coordinate system is located in the lower left corner. The unit is 1/72 inches in both directions. The extent is defined by the dimensions of the job.

This coordinate system is used in prepress for specifying the position of register marks, color measuring fields, and color control strips. In addition it is also the exact area covered by the preview images.

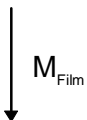

The relation between the PostScript coordinate system and the film coordinate system is defined by the offset between the two origins.



The origin of the film coordinate system is defined by the lower left corner of the film. The unit is 1/72 inches in both directions. The extent is defined by the dimensions of the film.

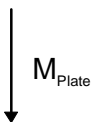

The relation between the film coordinate system and the plate coordinate system is defined by the offset between the two origins.

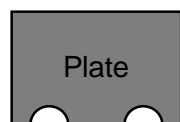

The origin of the plate coordinate system is defined by the lower left corner of the plate. The unit is 1/72 inches in both directions. The extent is defined by the dimensions of the plate.

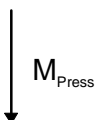

The relation between the plate coordinate system and the press coordinate system is defined by the offset between the two origins.



The press coordinate system is defined by the maximum print area of the press. The origin is located in the lower left corner. The unit is 1/72 inches in both directions. Start of print is at the bottom, while end of print is at the top.

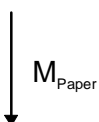

The relation between the press coordinate system and the paper coordinate system is defined by the offset between the two origins.

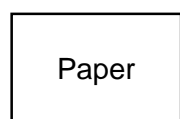

The origin of the paper coordinate system is defined by the lower left corner of the paper. The unit is 1/72 inches in both directions. The extent is defined by the dimensions of the paper.

The following steps are necessary to transform a coordinate (e.g. the position of a color measuring field) from the PostScript coordinate system to the paper coordinate system:

- clip coordinate at PS extent (i.e. check if coordinate is inside the extent)
- transform coordinate to film coordinate system
- clip coordinate at film extent
- transform coordinate to plate coordinate system
- clip coordinate at plate extent
- transform coordinate to press coordinate system
- clip coordinate at press extent
- transform coordinate to paper coordinate system
- clip coordinate at paper coordinate system

If a number of coordinates have to be transformed by the same sequence of transformations, it is useful to calculate the combined transformation matrix by concatenating the elementary transformation matrices. If clipping is important, a combined clipping region can be calculated (which may not be rectangular).

2.3 Block-based Coordinate Systems

Within CIP3 PPF it is possible to define a hierarchy of nested cut blocks (see chapter 3.9 “Cutting Data” of CIP3 PPF Specification Version 3.0). The position and orientation of a cut block is specified relative to the parent block by the **CIP3BlockTrf** attribute. If the cut block is the root of the hierarchy of cut blocks, the position and orientation is specified relative to the PostScript coordinate system.

The transformation matrix specified by the **CIP3BlockTrf** attribute can directly be used to transform a coordinate of the cut block into the coordinate system of the parent block (or the PostScript coordinate system, if the cut block is the root of the cut block hierarchy):

$$P1_{\text{ParentBlock}} = P1_{\text{Block}} \times \text{Trf}_{\text{Block}}$$

An example can be found in chapter 2.6 “Coordinate Systems Used in the Product Definition Section” on page 14.

2.4 Relation Between Coordinate Systems of Different Surfaces or Print Runs

For one sheet, there can be two chains of coordinate systems: one for the front surface and one for the back surface. The two chains meet at the paper coordinate system. Of course, both paper extents must be exactly the same.

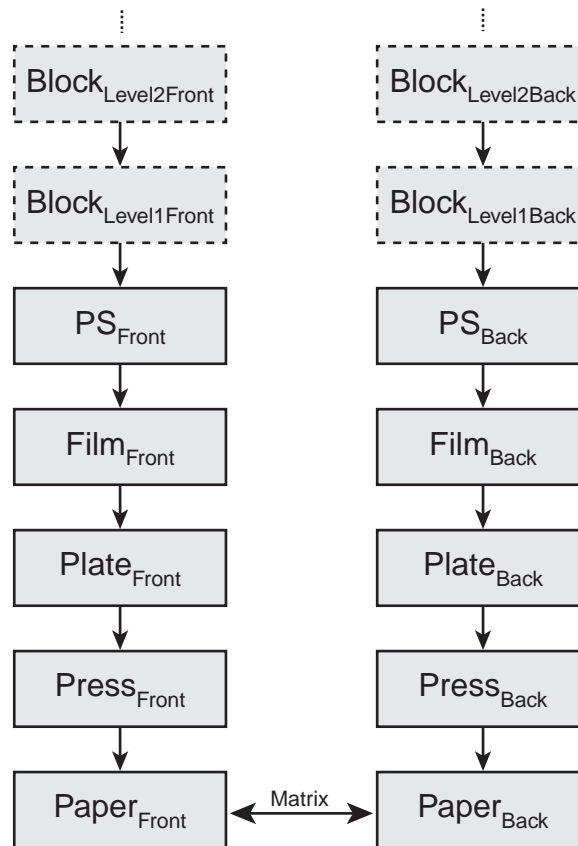

Illustration 2-2: Coordinate systems

The arrows indicate how the transformation between the two coordinate systems is defined. If a transformation in the opposite direction is required, the inverse matrix has to be calculated.

The relation between the two paper coordinate systems is given implicitly by the (newly defined) **CIP3AdmWorkStyle** attribute (see chapter 5 “New Attributes” on page 64 for the definition of this attribute). The attribute can have one of the following values: **/Simplex**, **/WorkAndBack**, **/Perfecting**, **/WorkAndTurn**, **/WorkAndTumble**, and **/WorkAndTwist**.

Work Style: Simplex

Only one side of the sheet (or web) is printed. There is one press run only.

Work Styles: WorkAndBack, Perfecting, WorkAndTurn, and WorkAndTumble

When printing on both surfaces of a sheet (or web), it is often necessary to transform coordinates of one surface to a coordinate system on the other surface. This can be done by using the transformation matrix specified in column 6 of Table 2-1: “Work Styles” on page 11. The matrix defines the transformation from the paper coordinate system of the front surface to the paper coordinate system of the back surface. Since all of the matrices specified in this table are “symmetric matrices”, they can also be used to perform the transformation in the other direction (i.e. from the back surface to the front surface).

Work Style: WorkAndTwist

When printing on the same surface of a sheet in two print runs, it is also often necessary to transform coordinates between coordinate systems of the different print runs. This can be done by using the transformation matrix given in the last row of table 2-1 in the same way as described above.

Work Style	Number of Plate Sets	Structure Containing Data	Number of Press Runs	Number of Surfaces Printed	Transformation Matrix (w = sheet width, h = sheet height)	Front Guiding Edge Changes	Side Guiding Edge Changes	Sheet Lay Changes
/Simplex	1	<i>Front</i>	1	1	-	-	-	-
/WorkAndBack	2	<i>Front</i> and <i>Back</i>	2	2	$[-1 \ 0 \ 0 \ 1 \ w \ 0]$	no	no	yes
/Perfecting	2	<i>Front</i> and <i>Back</i>	1	2	$[1 \ 0 \ 0 \ -1 \ 0 \ h]$	yes	no	-
/WorkAndTurn	1	<i>Front</i>	2	2	$[-1 \ 0 \ 0 \ 1 \ w \ 0]$	no	no	yes
/WorkAndTumble	1	<i>Front</i>	2	2	$[1 \ 0 \ 0 \ -1 \ 0 \ h]$	yes	no	no
/WorkAndTwist	1	<i>Front</i>	2	1	$[-1 \ 0 \ 0 \ -1 \ w \ h]$	yes	yes	no

Table 2-1: Work Styles

The following illustration shows the relation between the coordinate systems used for front and back (or the 1st and the 2nd press run respectively).

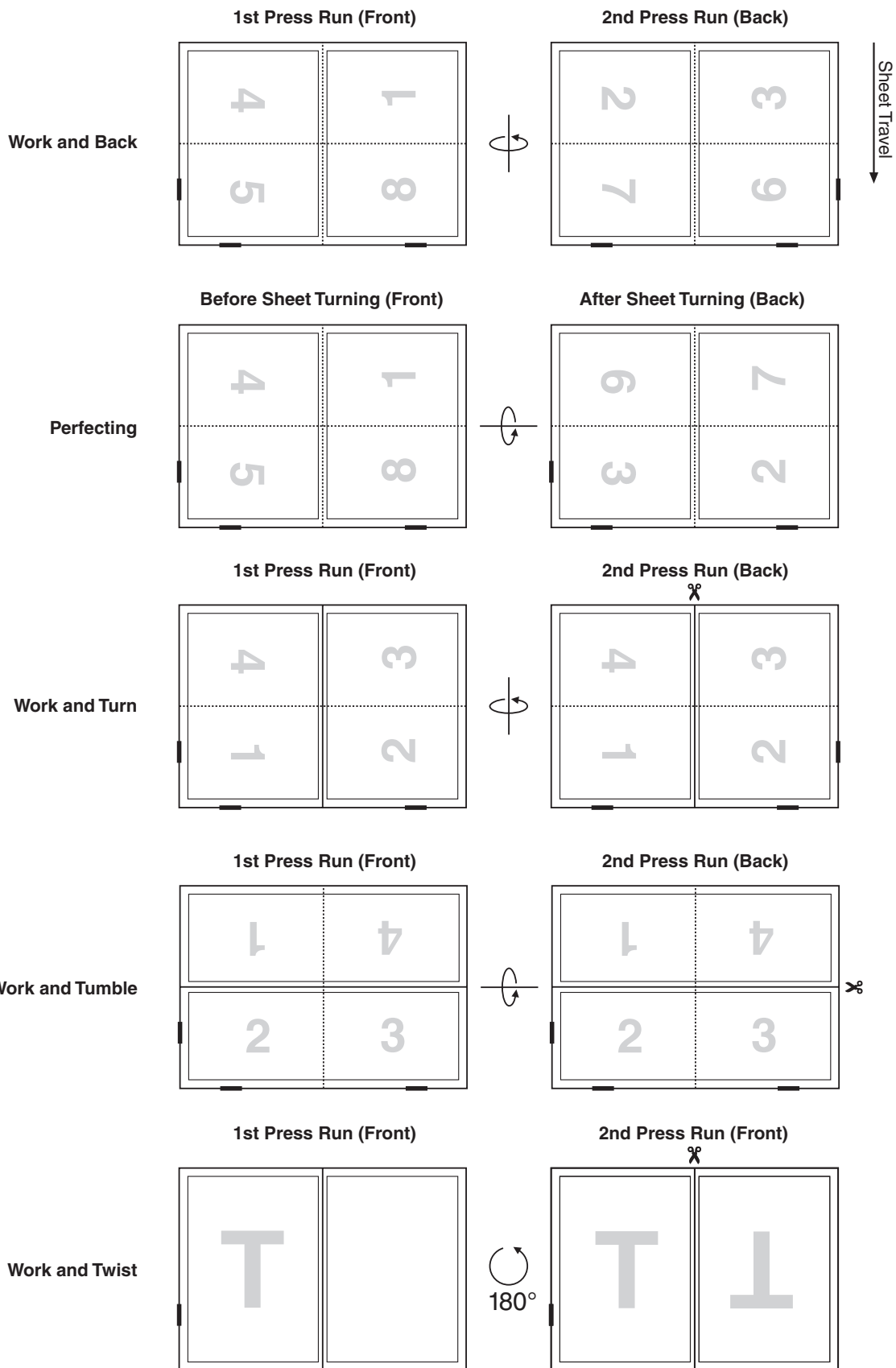

Illustration 2-3: Relation between coordinate systems of different surfaces or print runs

2.5 Coordinate System Used for Folding

Folding can be specified in two places within a CIP3 PPF file. The folding of sheets is specified in the **FoldProcedures** section (see chapter 3.10 “Folding Data” of the CIP3 PPF specification version 3.0) , while the folding of partial products is specified in the **Product Definition** section (see chapter 3.3.2.11 “Folding” of the CIP3 PPF specification version 3.0). The following illustration explains how the coordinate system is changed with the execution of each step of a folding procedure.

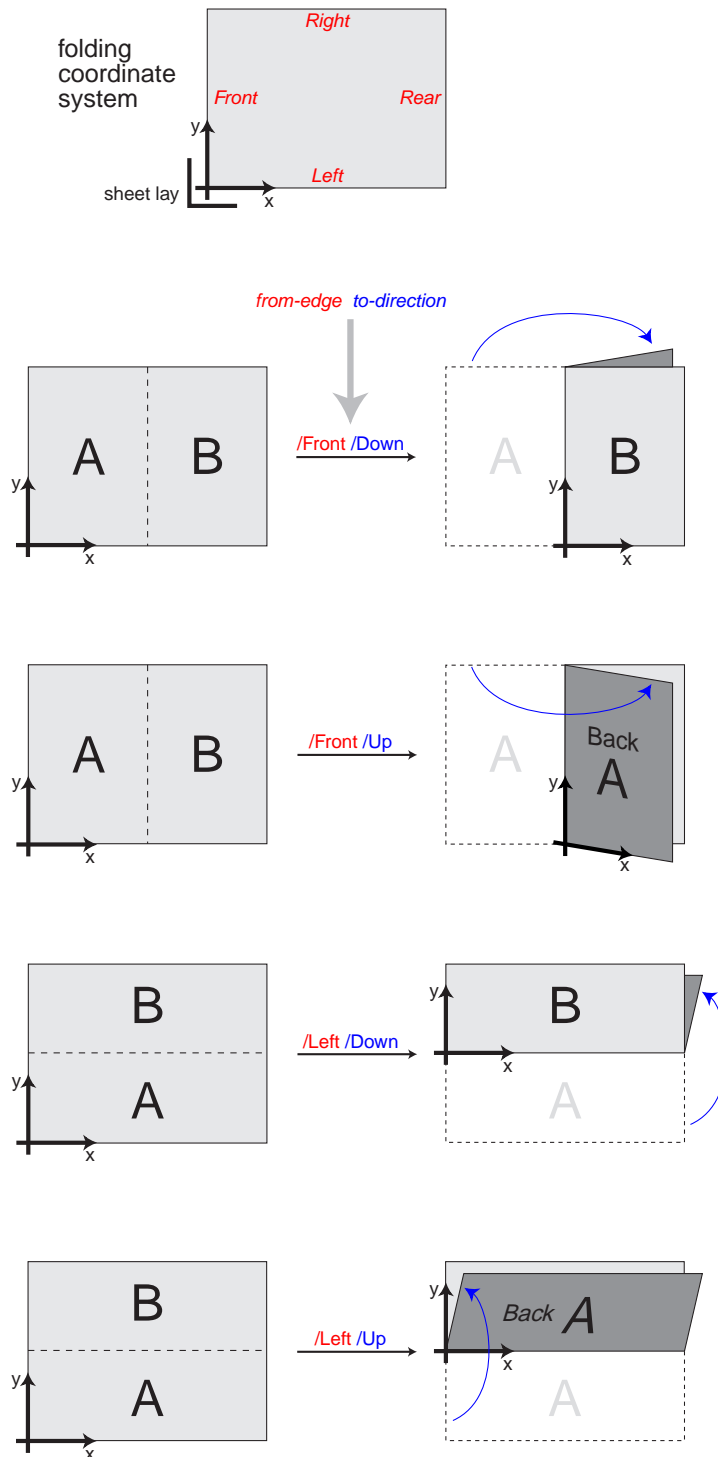

Illustration 2-4: Coordinate system used for folding

2.6 Coordinate Systems Used in the Product Definition Section

The table shown below is a corrected and improved version of table 3-9 of CIP3 PPF Specification Version 3.0 (page 31). It shows examples of often used matrices. Each two matrices shown in a row are inverse to each other. It is important to know that **w** and **h** are the width and the height of the object in the **source** coordinate system.

Source Coordinate System of Transformation 1	Transformation 1	Target Coordinate System of Trf. 1 and Source Coordinate System of Trf. 2	Transformation 2	Target Coordinate System of Transformation 2
	$[1 \ 0 \ 0 \ 1 \ 0 \ 0]$ No Action		$[1 \ 0 \ 0 \ 1 \ 0 \ 0]$ No Action	
	$[-1 \ 0 \ 0 \ -1 \ w \ h]$ Rotation by 180°		$[-1 \ 0 \ 0 \ -1 \ w \ h]$ Rotation by 180°	
	$[0 \ -1 \ 1 \ 0 \ 0 \ w]$ Rotation by 90° clockwise		$[0 \ 1 \ -1 \ 0 \ h \ 0]$ Rotation by 90° counter-clockwise	
	$[0 \ 1 \ -1 \ 0 \ h \ 0]$ Rotation by 90° counter-clockwise		$[0 \ -1 \ 1 \ 0 \ 0 \ w]$ Rotation by 90° clockwise	
	$[-1 \ 0 \ 0 \ 1 \ w \ 0]$ Horizontal Flip		$[-1 \ 0 \ 0 \ 1 \ w \ 0]$ Horizontal Flip	
	$[1 \ 0 \ 0 \ -1 \ 0 \ h]$ Vertical Flip		$[1 \ 0 \ 0 \ -1 \ 0 \ h]$ Vertical Flip	
	$[0 \ 1 \ 1 \ 0 \ 0 \ 0]$ Rotation by 90° counter-clockwise + Horizontal Flip		$[0 \ 1 \ 1 \ 0 \ 0 \ 0]$ Rotation by 90° counter-clockwise + Horizontal Flip	
	$[0 \ -1 \ -1 \ 0 \ w \ h]$ Rotation by 90° clockwise + Horizontal Flip		$[0 \ -1 \ -1 \ 0 \ h \ w]$ Rotation by 90° clockwise + Horizontal Flip	

Table 2-2: Matrices used to change the orientation

2.7 Example

Example 2-3: Cut block coordinates

This is a more detailed example with nested cut blocks.

```

%!PS-Adobe-3.0
%%CIP3-File Version 3.0
...
CIP3BeginSheet
/CIP3AdmJobName (Coordinate example) def
...
/CIP3AdmPSExtent [ 450 mm 310 mm ] def
/CIP3AdmFilmTrf [ 1 0 0 1 50 mm 80 mm ] def
/CIP3AdmFilmExtent [ 550 mm 420 mm ] def
/CIP3AdmPlateTrf [ 1 0 0 1 10 mm 20 mm ] def
/CIP3AdmPlateExtent [ 570 mm 440 mm ] def
/CIP3AdmPressTrf [ 1 0 0 1 40 mm 60 mm ] def
/CIP3AdmPressExtent [ 660 mm 500 mm ] def
/CIP3AdmPaperTrf [ 1 0 0 1 -70 mm -140 mm ] def
/CIP3AdmPaperExtent [ 440 mm 310 mm ] def
...
CIP3BeginCutData
  CIP3BeginCutBlock
    /CIP3BlockTrf [1 0 0 1 20 mm 30 mm] def
    /CIP3BlockSize [200 mm 260 mm] def
    /CIP3BlockType /TempBlock def
    /CIP3BlockName (Left Block) def
    CIP3BeginCutBlock
      /CIP3BlockTrf [1 0 0 1 100 mm 130 mm] def
      /CIP3BlockSize [100 mm 130 mm] def
      /CIP3BlockType /TempBlock def
      /CIP3BlockName (Block 3) def
      20 mm 30 mm /LowerLeftCutMark CIP3PlaceCutMark
      ...
    CIP3EndCutBlock
  CIP3EndCutBlock
  CIP3BeginCutBlock
    /CIP3BlockTrf [1 0 0 1 430 mm 30 mm] def
    /CIP3BlockSize [200 mm 260 mm] def
    /CIP3BlockType /TempBlock def
    /CIP3BlockName (Right Block) def
  CIP3EndCutBlock
CIP3EndCutData
...
CIP3EndSheet
%%CIP3EndOfFile

```

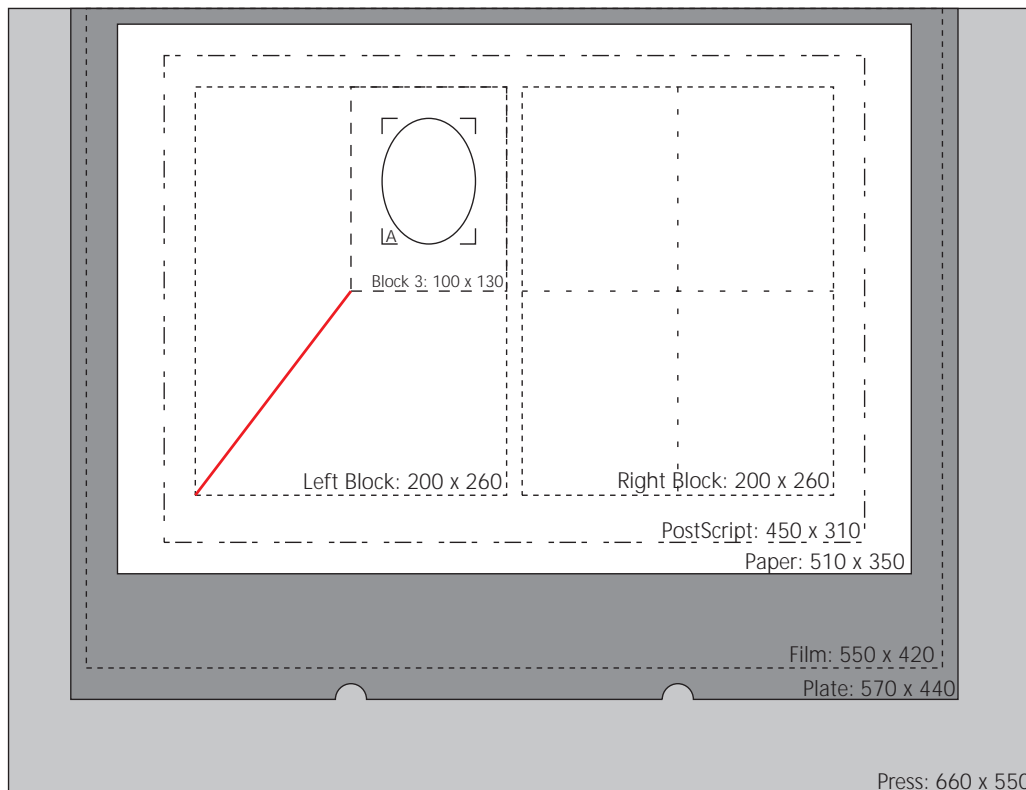

In this example, the position of the cut mark *A* is given in the coordinate system of *Block 3*. Let's call this position A_{Block3} . Since *Block 3* is directly nested within the *Left Block*, the position A_{Block3} can be transformed into a position within the coordinate system of the *Left Block*. This position can then be called $A_{LeftBlock}$. The transformation is performed by multiplying position A_{Block3} with the block transformation of *Block 3* as specified by the *CIP3BlockTrf* attribute within *Block 3*:

$$A_{LeftBlock} = A_{Block3} \times Trf_{Block3}$$

$$A_{LeftBlock} = [20 \ 30 \ 1] \times \begin{bmatrix} 1 & 0 & 0 \\ 0 & 1 & 0 \\ 100 & 130 & 1 \end{bmatrix} = [120 \ 160 \ 1]$$

Thus, the position of cut mark *A* within the coordinate system of the *Left Block* is (120, 160). In the same way the position of cut mark *A* can be transformed into all other coordinate systems:

$$A_{PS} = A_{Block3} \times Trf_{Block3} \times Trf_{LeftBlock}$$

$$A_{PS} = [20 \ 30 \ 1] \times \begin{bmatrix} 1 & 0 & 0 \\ 0 & 1 & 0 \\ 100 & 130 & 1 \end{bmatrix} \times \begin{bmatrix} 1 & 0 & 0 \\ 0 & 1 & 0 \\ 20 & 30 & 1 \end{bmatrix} = [140 \ 190 \ 1]$$

$$A_{Film} = A_{Block3} \times Trf_{Block3} \times Trf_{LeftBlock} \times Trf_{Film}$$

$$A_{Film} = [20 \ 30 \ 1] \times \begin{bmatrix} 1 & 0 & 0 \\ 0 & 1 & 0 \\ 100 & 130 & 1 \end{bmatrix} \times \begin{bmatrix} 1 & 0 & 0 \\ 0 & 1 & 0 \\ 20 & 30 & 1 \end{bmatrix} \times \begin{bmatrix} 1 & 0 & 0 \\ 0 & 1 & 0 \\ 50 & 80 & 1 \end{bmatrix} = [190 \ 270 \ 1]$$

$$A_{Plate} = A_{Block3} \times Trf_{Block3} \times Trf_{LeftBlock} \times Trf_{Film} \times Trf_{Plate}$$

$$A_{\text{Plate}} = \begin{bmatrix} 20 & 30 & 1 \end{bmatrix} \times \begin{bmatrix} 1 & 0 & 0 \\ 0 & 1 & 0 \\ 100 & 130 & 1 \end{bmatrix} \times \begin{bmatrix} 1 & 0 & 0 \\ 0 & 1 & 0 \\ 20 & 30 & 1 \end{bmatrix} \times \begin{bmatrix} 1 & 0 & 0 \\ 0 & 1 & 0 \\ 50 & 80 & 1 \end{bmatrix} \times \begin{bmatrix} 1 & 0 & 0 \\ 0 & 1 & 0 \\ 10 & 20 & 1 \end{bmatrix} = \begin{bmatrix} 200 & 290 & 1 \end{bmatrix}$$

$$A_{\text{Press}} = A_{\text{Block3}} \times \text{Trf}_{\text{Block3}} \times \text{Trf}_{\text{LeftBlock}} \times \text{Trf}_{\text{Film}} \times \text{Trf}_{\text{Plate}} \times \text{Trf}_{\text{Press}}$$

$$A_{\text{Press}} = \begin{bmatrix} 20 & 30 & 1 \end{bmatrix} \times \begin{bmatrix} 1 & 0 & 0 \\ 0 & 1 & 0 \\ 100 & 130 & 1 \end{bmatrix} \times \begin{bmatrix} 1 & 0 & 0 \\ 0 & 1 & 0 \\ 20 & 30 & 1 \end{bmatrix} \times \begin{bmatrix} 1 & 0 & 0 \\ 0 & 1 & 0 \\ 50 & 80 & 1 \end{bmatrix} \times \begin{bmatrix} 1 & 0 & 0 \\ 0 & 1 & 0 \\ 10 & 20 & 1 \end{bmatrix} \times \begin{bmatrix} 1 & 0 & 0 \\ 0 & 1 & 0 \\ 40 & 60 & 1 \end{bmatrix} = \begin{bmatrix} 240 & 350 & 1 \end{bmatrix}$$

$$A_{\text{Paper}} = A_{\text{Block3}} \times \text{Trf}_{\text{Block3}} \times \text{Trf}_{\text{LeftBlock}} \times \text{Trf}_{\text{Film}} \times \text{Trf}_{\text{Plate}} \times \text{Trf}_{\text{Press}} \times \text{Trf}_{\text{Paper}}$$

$$A_{\text{Paper}} = \begin{bmatrix} 20 & 30 & 1 \end{bmatrix} \times \begin{bmatrix} 1 & 0 & 0 \\ 0 & 1 & 0 \\ 100 & 130 & 1 \end{bmatrix} \times \begin{bmatrix} 1 & 0 & 0 \\ 0 & 1 & 0 \\ 20 & 30 & 1 \end{bmatrix} \times \begin{bmatrix} 1 & 0 & 0 \\ 0 & 1 & 0 \\ 50 & 80 & 1 \end{bmatrix} \times \begin{bmatrix} 1 & 0 & 0 \\ 0 & 1 & 0 \\ 10 & 20 & 1 \end{bmatrix} \times \begin{bmatrix} 1 & 0 & 0 \\ 0 & 1 & 0 \\ 40 & 60 & 1 \end{bmatrix} \times \begin{bmatrix} 1 & 0 & 0 \\ 0 & 1 & 0 \\ -70 & -140 & 1 \end{bmatrix} \\ = \begin{bmatrix} 170 & 210 & 1 \end{bmatrix}$$

The following table summarizes the position of cut mark A:

Coordinate system	Position of cut mark A
Block 3	20 mm, 30 mm
Left Block	120 mm, 160 mm
PostScript	140 mm, 190 mm
Film	190 mm, 270 mm
Plate	200 mm, 290 mm
Press	240 mm, 350 mm
Paper	170 mm, 210 mm

Table 2-3: Position of cut mark A in all coordinate systems

3 Web Printing Extensions

This chapter describes some extensions to CIP3 PPF for web printing applications. Most of the definitions given here do not specify new CIP3 PPF objects, but instead explain and define how the objects already defined in CIP3 PPF version 3.0 can be used for web printing applications. Nevertheless, a few new items are added, like the *Dividing* and *Gluing* operations.

3.1 Specification

The changes can be categorized as follows:

- *Explanation*. Provides a better explanation of an aspect of the current CIP3 PPF specification Version 3.0. It does not explicitly imply any changes to the syntax or semantics of CIP3 PPF. Therefore it can also be applied to CIP3 PPF Version 3.0.
- *Web printing requirement*. Specifies an additional requirement (e.g. for attributes), which is only valid for web printing applications.
- *New operation*. Defines a new operation in the **Product Definition** section.
- *New definition*. A new attribute is defined in the **Product Definition** section.

3.1.1 Explanations

The following illustration shows the press coordinate system used for web printing.

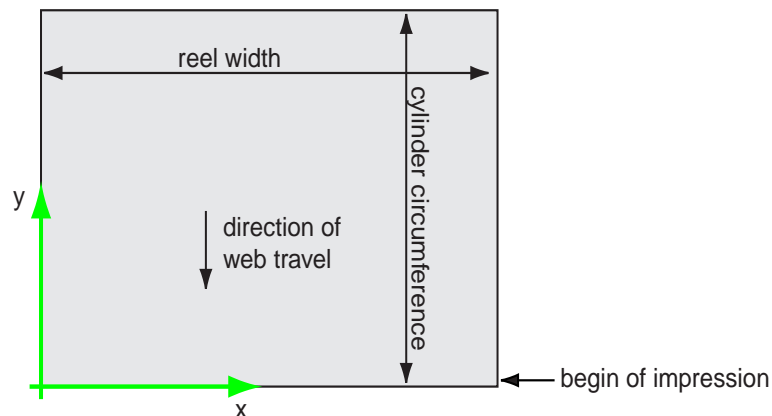

Illustration 3-1: Coordinate system used for web printing

Each web of a web printing job is described within CIP3 PPF as one sheet. Jobs using multiple webs must be described with a CIP3 PPF file containing multiple sheets.

- Folding in the former is described by the **Folding** operation in the **Product Definition** section.
- Slitting and cross cutting are both described by the **Dividing** operation in the **Product Definition** section. This is a new operation.

- Gathering of ribbons is described by the Gathering operation in the **Product Definition** section.
- Gluing of ribbons is described by the Gluing operation in the **Product Definition** section. This is a new operation.

3.1.2 Web Printing Requirements

In a CIP3 PPF file created for web printing, the following CIP3 attributes must be defined (although they are marked as optional in the CIP3 PPF Specification).

Structure	Attribute	Value
Sheet	CIP3AdmPaperSource	/Reel
Sheet	CIP3AdmReelWidth	reel width
Sheet	CIP3AdmCylinderCircumference	cylinder circumference

Table 3-1: Attributes required for web printing applications

3.1.3 New Operations

Two new operations are defined: Dividing and Gluing.

3.1.3.1 Dividing

This operation describes the dividing process. The operation type, which is specified by the **CIP3ProductOperation** attribute, must be set to **/Dividing**.

The operation requires one input component, the web, sheets, or signatures to be divided.

The operation can have multiple output components, called subproducts. A subproduct can be referenced by defining a component definition dictionary with the following entries:

- **/SourceType** **/SubProduct**
- **/SourceProduct** (*name of corresponding partial product*)
- **/SourceSubProduct** (*name of subproduct*)

Key Name	Type	Necessary	Meaning
DividingType	name	required	Cut direction: /FirstCrossCut (the first cut parallel to the X-axis), /CrossCut (a cut parallel to the X-axis) or /Slitting (a cut parallel to the Y-axis).
DividingPositions	array of numbers	required	Array containing the cut positions. If the cut direction given by DividingType is /CrossCut or /FirstCrossCut , this array contains Y coordinates. If the cut direction is /Slitting , it contains X coordinates.
SubProductNames	array of strings	<i>see meaning</i>	Array containing the names of the resulting subproducts. The names must be given in the sequence from bottom to top (for /CrossCut), or from left to right (for /Slitting). For /CrossCut and /Slitting , this array must contain exactly one element more than the DividingPositions array. For /FirstCrossCut , the array must contain exactly the same number of element as the DividingPositions array. If only one cross cut is defined, the SubProductNames array can be omitted. In this case the output component must be referenced as a PartialProduct instead of a SubProduct .

Table 3-2: Operation-specific dictionary for **Dividing** operation

Key Name	Type	Necessary	Meaning
Orientation	matrix	required	Matrix describing the orientation of the component.

Table 3-3: Component-specific dictionary for **Dividing operation**

Example 3-1: Example: A web is slitted into three ribbons, which then are gathered.

```

CIP3BeginProductDefinition
/CIP3Products
[
  <<
    /CIP3ProductName (three ribbons)
    /CIP3ProductOperation /Dividing
    /CIP3ProductParams
      <</DividingType /Slitting
        /DividingPositions [ 10 cm 20 cm ]
        /SubProductNames [ (A) (B) (C) ]
      >>
    /CIP3ProductComponents
    [ <</SourceType /Sheet
      /SourceSheet (Web 1)
      /Params << /Orientation [1 0 0 1 0 0] >>
    >>
    ]
  >>
  <<
    /CIP3ProductName (gathered parts)
    /CIP3ProductOperation /Gathering
    /CIP3ProductComponents
    [ <</SourceType /SubProduct
      /SourceProduct (three ribbons)
      /SourceSubProduct (C)
      /Params << /Orientation [1 0 0 1 0 0] >>
    >>
      <</SourceType /SubProduct
        /SourceProduct (three ribbons)
        /SourceSubProduct (B)
        /Params << /Orientation [1 0 0 1 0 0] >>
      >>
      <</SourceType /SubProduct
        /SourceProduct (three ribbons)
        /SourceSubProduct (A)
        /Params << /Orientation [1 0 0 1 0 0] >>
      >>
    ]
  >>
] def
/CIP3FinalProducts [ (gathered parts) ] def
CIP3EndProductDefinition

```

3.1.3.2 Gluing

This operation describes the gluing process. The operation type, which is specified by the **CIP3ProductOperation** attribute, must be set to **/Gluing**.

The operation requires one component, the sheet or signature to be glued.

Key Name	Type	Necessary	Meaning
GlueLines	array of dictionaries	required	Array of GlueLine dictionaries (see CIP3 PPF Specification Version 3.0).

Table 3-4: Operation-specific dictionary for **Gluing operation**

Key Name	Type	Necessary	Meaning
Orientation	matrix	required	Matrix describing the orientation of the component.

Table 3-5: Component-specific dictionary for **Gluing operation**

Example 3-2: Example: Sheet is cut into three pieces, which then are gathered.

```

CIP3BeginProductDefinition
/CIP3Products
[
  <<
    /CIP3ProductName (ribbon with two glue lines)
    /CIP3ProductOperation /Gluing
    /CIP3ProductParams
      <</GlueLines [<< /StartPosition [ 0 cm 30 cm ]
                    /WorkingPath [ 86 cm 0 cm]
                    /GlueType /Hotmelt
                    /GluingPattern []% solid line
                    >>
                << /StartPosition [ 0 cm 60 cm ]
                    /WorkingPath [ 86 cm 0 cm]
                    /GlueType /Hotmelt
                    /GluingPattern []% solid line
                >>
      >>
    ]
  >>
  /CIP3ProductComponents
  [ <</SourceType /SubProduct
    /SourceProduct (ribbon)
    /SourceSubProduct (pages 3, 4, 5, 6, 11, 12, 13, 14)
    /Params << /Orientation [1 0 0 1 0 0] >>
  >>
  ]
  >>
  % ... more product defintion steps would go here ...
] def
CIP3EndProductDefinition

```

3.1.4 New Definitions

3.1.4.1 Encoding of Product Definition Hierarchy

The product definition hierarchy is used to describe a set of related products (e.g. different issues or editions of a newspaper). It is stored in the **CIP3ProductHierarchy** attribute of the **Product Definition** section.

Attribute Name	Type	Necessary	Meaning
CIP3Products	array of dictionaries	required	Array containing all Product Definition dictionaries (see Table 3-7: "Product definition dictionary" in CIP3 PPF Specification Version 3.0 on page 26)
CIP3FinalProducts	array of strings	required	Names of products (not including the partial products)
CIP3ProductHierarchy	dict	optional	Node Dictionary of highest node of the product hierarchy. It contains (directly or indirectly) all other node dictionaries. All nodes together describe the complete product definition hierarchy.

Table 3-6: Attributes of *Product Definition* section

There are four predefined hierarchy levels:

- **Title** The title is the general name of a publication. It is the highest level of the product definition hierarchy.
Examples: "New York Times", "Le Monde", "Frankfurter Allgemeine".
- **Issue** The issue is a variation of a title, specific to a particular date or time.
Example: "the New York Times from Wednesday, January 26, 2000".
- **Edition** The edition is a variation of a title or an issue, specific to a particular geographical delivery area.
Example: "New York Times, East Coast Edition".
- **Edition Version** The Edition Version is a variation of an Edition. An Edition Version may differ from others in price, language, ads, local geographical area etc. There can be several nested hierarchy levels of Edition Versions.
Example: A "Zone" is an Edition Version which is specific to a local delivery area.

The nesting of hierarchy levels is restricted by the following rules:

- A Title node may only contain a set of Issue nodes or a set of Edition nodes (or nothing).
- An Issue node may only contain a set of Edition nodes (or nothing).
- An Edition node may only contain a set of Edition Version nodes (or nothing).
- An Edition Version node may only contain a set of Edition Version nodes (or nothing).

Key Name	Type	Necessary	Meaning
Type	name	required	Type of hierarchy node: /Title , /Issue , /Edition , or /EditionVersion .
Name	string	required	Name of hierarchy node (i.e. Title name, Issue name, Edition name, or name of an EditionVersion).
Volume	integer	optional	Volume number. <i>This attribute may only be defined within a leaf node of the product hierarchy.</i>
Date	string	optional	Date and/or time of product. <i>This attribute is coded the same way as the CIP3AdmCreationTime attribute.</i>
FinalProduct	string	optional	Name of final product. This string must match one of the final product names listed in CIP3FinalProducts (see Product Definition Section of CIP3 PPF Specification Version 3.0). <i>This attribute may only be defined within a leaf node of the product hierarchy.</i>
Children	array of dictionaries	optional	Array containing the nested hierarchy nodes. <i>This attribute may only be defined within a non-leaf node of the product hierarchy.</i>

Table 3-7: Node Dictionary of Product Definition Hierarchy

Example 3-3: Example: Product Definition Hierarchy

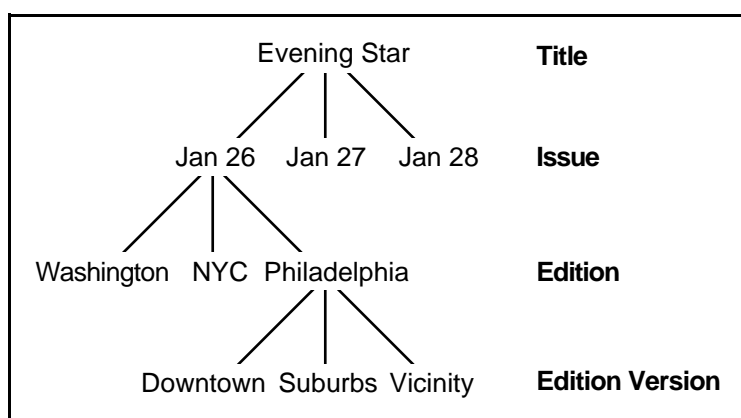

Illustration 3-2: Example of Product Definition Hierarchy

Please note that in practice the two issues of January 27 and January 28 would branch out further or contain a Final Product.

Code example using PostScript-based Encoding:

```

CIP3BeginProductDefinition
/CIP3Products [
% ... the definition of all partial and final products would go here ...
] def
/CIP3FinalProducts [
(Evening Star, 26-Jan-2000, Washington Edition)
(Evening Star, 26-Jan-2000, New York Edition)
(Evening Star, 26-Jan-2000, Philadelphia Downtown)
(Evening Star, 26-Jan-2000, Philadelphia Suburbs)
(Evening Star, 26-Jan-2000, Philadelphia Vicin.)
] def
/CIP3ProductHierarchy
<</Type /Title
/Name (Evening Star)
/Children
[
<</Type /Issue
/Name (January 26)
/Date (Wed Jan 26 00:00:00 2000)
/Children
[
<</Type /Edition
/Name (Washington)
/FinalProduct (Evening Star, 26-Jan-2000, Washington Edition)
>>
<</Type /Edition
/Name (New York)
/FinalProduct (Evening Star, 26-Jan-2000, New York Edition)
>>
<</Type /Edition
/Name (Philadelphia)
/Children
<</Type /EditionVersion
/Name (Downtown)
/FinalProduct (Evening Star, 26-Jan-2000, Philadelphia Downtown)
>>
<</Type /EditionVersion
/Name (Suburbs)
/FinalProduct (Evening Star, 26-Jan-2000, Philadelphia Suburbs)
>>
<</Type /EditionVersion
/Name (Vicinity)
/FinalProduct (Evening Star, 26-Jan-2000, Philadelphia Vicin.)
>>
>> % end Edition
]
>>
<</Type /Issues
/Name (January 27)
/Date (Thu Jan 27 00:00:00 2000)
>>
<</Type /Issues
/Name (January 28)
/Date (Fri Jan 28 00:00:00 2000)
>>
]
>> % end Title
def
CIP3EndProductDefinition

```

3.2 Web Printing Examples

The following examples are given to demonstrate the specifications introduced in the previous chapter.

- ↓ Direction of Web Travel
- ▼ Position of Former
- ✂ Position of Slit or Cross-Cut
- Position of Cross-Fold
- ⌞ Position of 3rd Fold (Longitudinal)
- • • Position of Pins

Illustration 3-3: Legend for example illustrations

3.2.1 Example: 16 Pages, Portrait

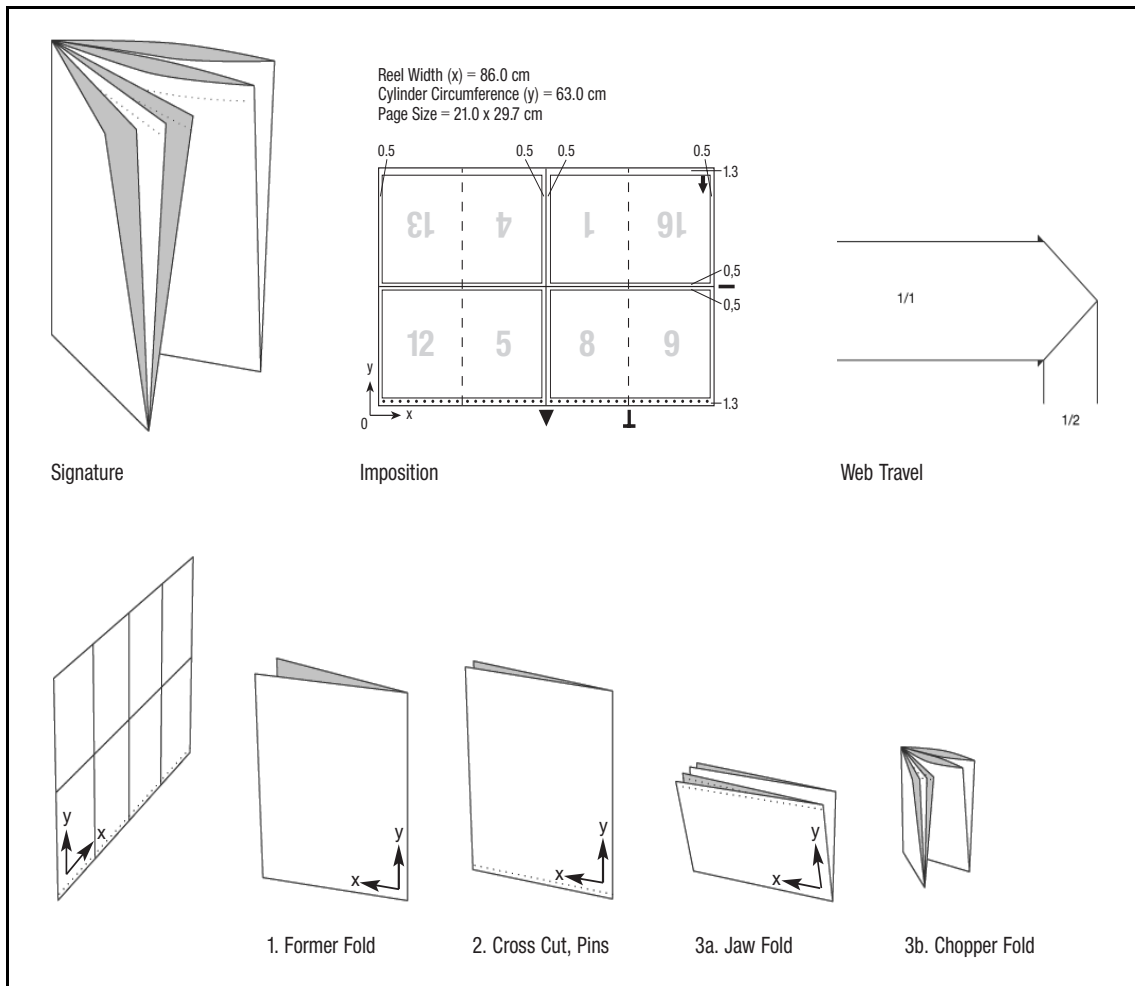

Illustration 3-4: "16 Pages, Portrait" Example

#	Operation	Implementation in CIP3 PPF
1	former fold	A partial product must be defined in the product definition section. The operation is /Folding . It requires one component, which must be the sheet describing the flat signature.
2	cross cut	A partial product must be defined in the product definition section. The operation is /Dividing . It requires one component, which must be the partial product specified in operation #1.
3	jaw fold, chopper fold	A partial product must be defined in the product definition section. The operation is /Folding . It requires one component, which must be the partial product specified in operation #2.

Table 3-8: Implementation of "16 Pages, Portrait" Example

CIP3 PPF Code for “16 Pages, Portrait” Example

```

%!PS-Adobe-3.0
%%CIP3-File Version 3.0
CIP3BeginPPFDirectory
...
CIP3EndPPFDirectory
CIP3BeginProductDefintion
/CIP3Products
[
  <<
    /CIP3ProductName (former folded)
    /CIP3ProductOperation /Folding
    /CIP3ProductParams
      <</CIP3FoldSheetIn [ 86 cm 63 cm ]
        /CIP3FoldProc [ 43 cm /Front /Down Fold ]
      >>
    /CIP3ProductComponents
    [ <</SourceType /Sheet
      /SourceSheet (Web 1)
      /Params << /Orientation [1 0 0 1 0 0] >>
    >>
  ]
>>
<<
  /CIP3ProductName (cross cut signature)
  /CIP3ProductOperation /Dividing
  /CIP3ProductParams
    <</DividingType /FirstCrossCut
      /DividingPositions [ 63 cm ]
    >>
  /CIP3ProductComponents
  [ <</SourceType /PartialProduct
    /SourceProduct (former folded)
    /Params << /Orientation [1 0 0 1 0 0] >>
  >>
  ]
>>
<<
  /CIP3ProductName (16 Pages, Portrait)
  /CIP3ProductOperation /Folding
  /CIP3ProductParams
    <</CIP3FoldSheetIn [ 43 cm 63 cm ]
      /CIP3FoldProc [ 31.5 cm /Left /Down Fold
        21.5 cm /Front /Down Fold ]
    >>
  /CIP3ProductComponents
  [ <</SourceType /PartialProduct
    /SourceProduct (cross cut signature)
    /Params << /Orientation [1 0 0 1 0 0] >>
  >>
  ]
>>
] def
/CIP3FinalProducts [(16 Pages, Portrait)] def
CIP3EndProductDefinition
...

```

```
CIP3BeginSheet
/CIP3AdmSheetName (Web 1)
/CIP3AdmPSExtent [ 86 cm 63 cm ] def
/CIP3AdmPaperSource /Reel def
/CIP3AdmReelWidth 86 cm def
/CIP3AdmCylinderCircumference 63 cm def
...
CIP3BeginFront
...
CIP3EndFront
CIP3BeginBack
...
CIP3EndBack
CIP3EndSheet
%%CIP3EndOfFile
```

3.2.2 Example: 16 Pages open, Portrait

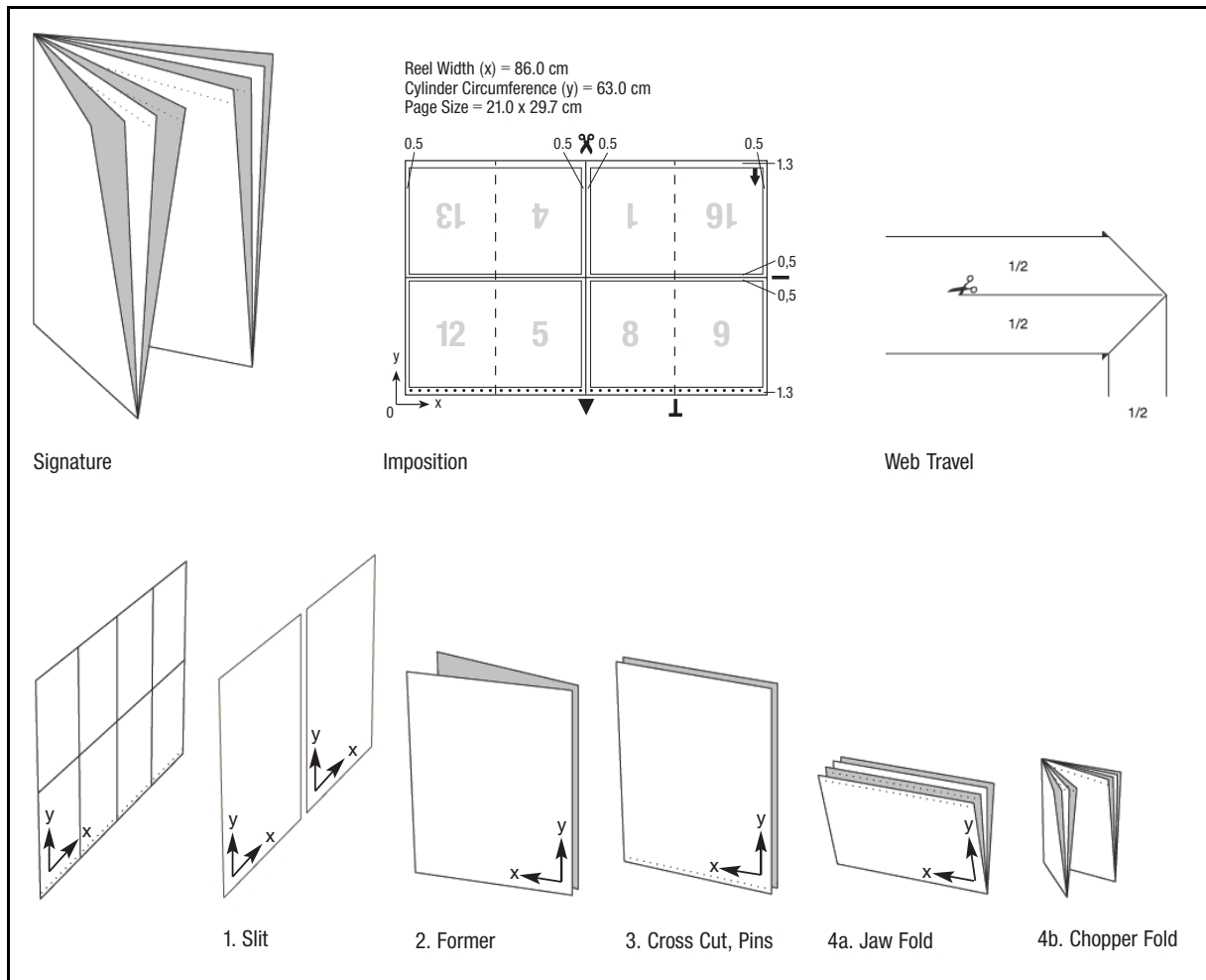

Illustration 3-5: "16 Pages open, Portrait" Example

#	Operation	Implementation in CIP3 PPF
1	slitting	A partial product must be defined in the product definition section. The operation is /Dividing . It requires one component, which must be the sheet describing the undivided and flat signature.
2	former	A partial product must be defined in the product definition section. The operation is /Gathering . It requires two components, which must be the two ribbons resulting from operation #1. One ribbon must be turned before gathering.
3	cross cut	A partial product must be defined in the product definition section. The operation is /Dividing . It requires one component, which must be the block specified in operation #2.
4	jaw fold, chopper fold	A partial product must be defined in the product definition section. The operation is /Folding . It requires one component, which must be the partial product specified in operation #3.

Table 3-9: Implementation of "16 Pages open, Portrait" Example

CIP3 PPF Code for “16 Pages open, Portrait” Example

```

%!PS-Adobe-3.0
%%CIP3-File Version 3.0
CIP3BeginPPFDirectory
...
CIP3EndPPFDirectory
CIP3BeginProductDefintion
/CIP3Products
[
  <<
    /CIP3ProductName (ribbons)
    /CIP3ProductOperation /Dividing
    /CIP3ProductParams
      <</DividingType /Slitting
        /DividingPositions [ 43 cm ]
        /SubProductNames [ (pages 3, 4, 5, 6, 11, 12, 13, 14)
                          (pages 1, 2, 7, 8, 9, 10, 15, 16) ]
      >>
    /CIP3ProductComponents
    [ <</SourceType /Sheet
      /SourceSheet (Web 1)
      /Params << /Orientation [-1 0 0 1 43 cm 0] >>
    >>
  ]
>>
<<
  /CIP3ProductName (gathered ribbons)
  /CIP3ProductOperation /Gathering
  /CIP3ProductComponents
  [ <</SourceType /SubProduct
    /SourceProduct (ribbons)
    /SourceSubProduct (pages 3, 4, 5, 6, 11, 12, 13, 14)
    /Params << /Orientation [-1 0 0 1 43 cm 0] >> % turn sheet
    >>
    <</SourceType /SubProduct
      /SourceProduct (ribbons)
      /SourceSubProduct (pages 1, 2, 7, 8, 9, 10, 15, 16))
      /Params << /Orientation [1 0 0 1 0 0] >>
    >>
  ]
>>
<<
  /CIP3ProductName (cross cut signature)
  /CIP3ProductOperation /Dividing
  /CIP3ProductParams
    <</DividingType /FirstCrossCut
      /DividingPositions [ 63 cm ]
    >>
  /CIP3ProductComponents
  [ <</SourceType /PartialProduct
    /SourceProduct (gathered ribbons)
    /Params << /Orientation [1 0 0 1 0 0] >>
    >>
  ]
>>

```

```
<<
  /CIP3ProductName (16 Pages open, Portrait)
  /CIP3ProductOperation /Folding
  /CIP3ProductParams
    << /CIP3FoldSheetIn [ 43 cm 63 cm ]
      /CIP3FoldProc [ 31.5 cm /Left /Down Fold
        21.5 cm /Front /Down Fold ]
    >>
  /CIP3ProductComponents
  [ << /SourceType /PartialProduct
    /SourceProduct (cross cut signature)
    /Params << /Orientation [1 0 0 1 0 0] >>
  >>
  ]
>>
] def
/CIP3FinalProducts [(16 Pages open, Portrait)] def
CIP3EndProductDefinition
...
CIP3BeginSheet
/CIP3AdmSheetName (Web 1)
/CIP3AdmPSExtent [ 86 cm 63 cm ] def
/CIP3AdmPaperSource /Reel def
/CIP3AdmReelWidth 86 cm def
/CIP3AdmCylinderCircumference 63 cm def
...
CIP3BeginFront
...
CIP3EndFront
CIP3BeginBack
...
CIP3EndBack
CIP3EndSheet
%%CIP3EndOfFile
```

3.2.3 Example: 16 Pages, Landscape

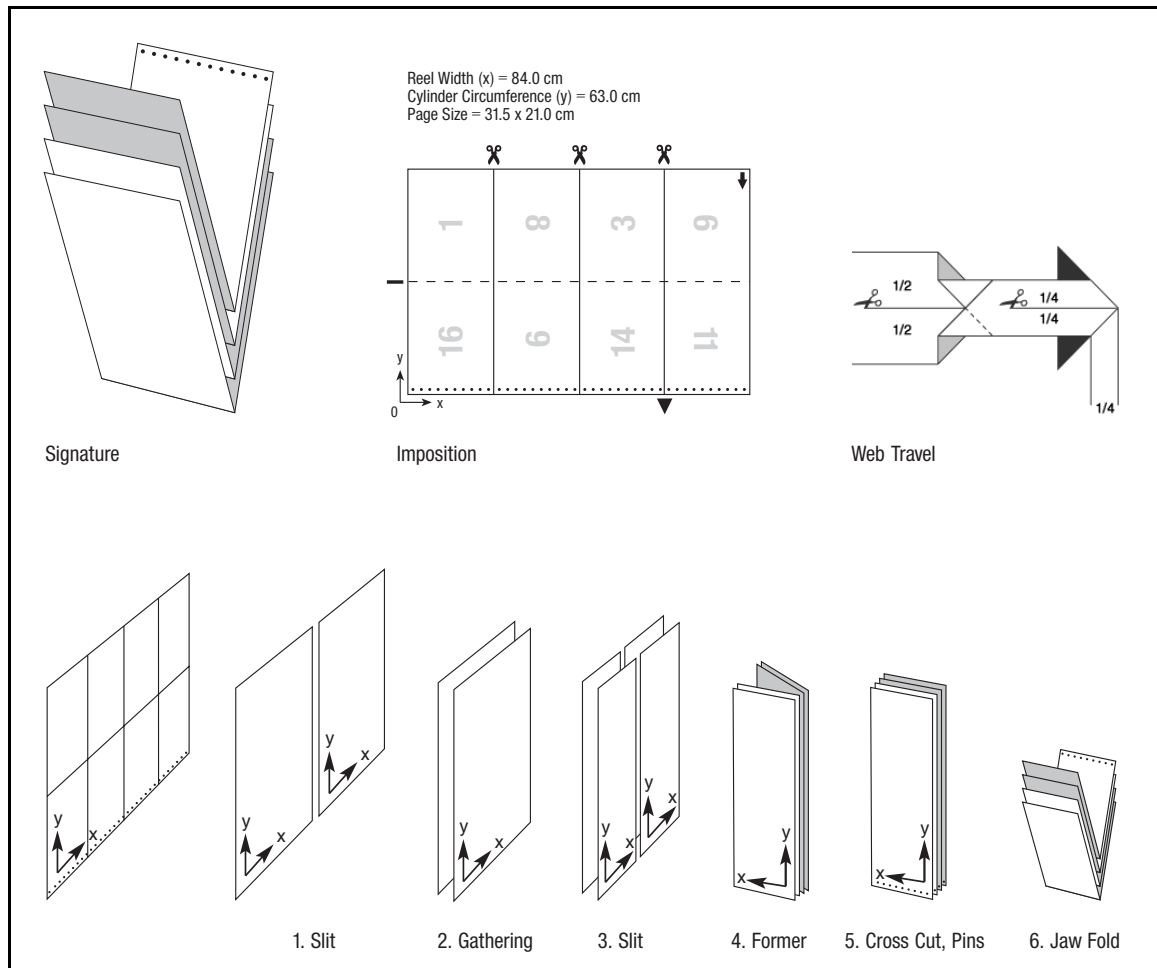

Illustration 3-6: "16 Pages, Landscape" Example

#	Operation	Implementation in CIP3 PPF
1	slitting	A partial product must be defined in the product definition section. The operation is /Dividing . It requires one component, which must be the sheet describing the undivided and flat signature.
2	gathering	A partial product must be defined in the product definition section. The operation is /Gathering . It requires two components, which must be the two ribbons resulting from operation #1.
3	slitting	A partial product must be defined in the product definition section. The operation is /Dividing . It requires one component, which must be the gathered ribbons resulting from operation #2.
4	former	A partial product must be defined in the product definition section. The operation is /Gathering . It requires two components, which must be the two sets of gathered ribbons resulting from operation #3.
5	cross cut	A partial product must be defined in the product definition section. The operation is /Dividing . It requires one component, which must be the gathered ribbons resulting from operation #4.
6	jaw fold	A partial product must be defined in the product definition section. The operation is /Folding . It requires one component, which must be the partial product specified in operation #5.

Table 3-10: Implementation of “16 Pages, Landscape” Example

CIP3 PPF Code for “16 Pages, Landscape” Example

```

%!PS-Adobe-3.0
%%CIP3-File Version 3.0
CIP3BeginPPFDirectory
...
CIP3EndPPFDirectory
CIP3BeginProductDefintion
/CIP3Products
[
  <<
    /CIP3ProductName (first slit)
    /CIP3ProductOperation /Dividing
    /CIP3ProductParams
      <</DividingType /Slitting
        /DividingPositions [ 42 cm ]
        /SubProductNames [ (pages 1, 2, 7, 8, 9, 10, 15, 16)
                          (pages 3, 4, 5, 6, 11, 12, 13, 14) ] ...
      >>
    /CIP3ProductComponents
    [ <</SourceType /Sheet
      /SourceSheet (Web 1)
      /Params <</Orientation [1 0 0 1 0 0] >>
    >>
  ]
>>
<<
  /CIP3ProductName (gathered ribbons)
  /CIP3ProductOperation /Gathering
  /CIP3ProductComponents
  [ <</SourceType /SubProduct
    /SourceProduct (first slit)
    /SourceBlock (pages 3, 4, 5, 6, 11, 12, 13, 14)
    /Params <</Orientation [1 0 0 1 0 0] >>
    >>
    <</SourceType /SubProduct
    /SourceProduct (first slit)
    /SourceBlock (pages 1, 2, 7, 8, 9, 10, 15, 16)
    /Params <</Orientation [1 0 0 1 0 0] >>
    >>
  ]
>>
<<
  /CIP3ProductName (second slit)
  /CIP3ProductOperation /Dividing
  /CIP3ProductParams
    <</DividingType /Slitting
      /DividingPositions [ 21 cm ]
      /SubProductNames [ (pages 1, 2, 3, 4, 13, 14, 15, 16)
                        (pages 5, 6, 7, 8, 9, 10, 11, 12) ] ...
    >>
  /CIP3ProductComponents
  [ <</SourceType /PartialProduct
    /SourceProduct (gathered ribbons)
    /Params <</Orientation [1 0 0 1 0 0] >>
    >>
  ]
>>

```

```

<<
  /CIP3ProductName (gathered ribbons at former)
  /CIP3ProductOperation /Gathering
  /CIP3ProductComponents
  [ << /SourceType /PartialProduct
    /SourceProduct (second slit/pages 1, 2, 3, 4, 13, 14, 15, 16)
    /Params << /Orientation [-1 0 0 1 21 cm 0] >>
    >>
    << /SourceType /PartialProduct
    /SourceProduct (second slit/pages 5, 6, 7, 8, 9, 10, 11, 12)
    /Params << /Orientation [1 0 0 1 0 0] >>
    >>
  ]
>>
<<
  /CIP3ProductName (cross cut)
  /CIP3ProductOperation /Dividing
  /CIP3ProductParams
    << /DividingType /FirstCrossCut
    /DividingPositions [ 63 cm ]
    >>
  /CIP3ProductComponents
  [ << /SourceType /PartialProduct
    /SourceProduct (gathered ribbons at former)
    /Params << /Orientation [1 0 0 1 0 0] >>
    >>
  ]
>>
<<
  /CIP3ProductName (16 Pages, Landscape)
  /CIP3ProductOperation /Folding
  /CIP3ProductParams
    << /CIP3FoldSheetIn [ 43 cm 63 cm ]
    /CIP3FoldProc [ 31.5 cm /Left /Up Fold ]
    >>
  /CIP3ProductComponents
  [ << /SourceType /PartialProduct
    /SourceProduct (cross cut)
    /Params << /Orientation [1 0 0 1 0 0] >>
    >>
  ]
>>
] def
/CIP3FinalProducts [(16 Pages, Landscape)] def
CIP3EndProductDefinition
...
CIP3BeginSheet
/CIP3AdmSheetName (Web 1)
/CIP3AdmPSExtent [ 86 cm 63 cm ] def
/CIP3AdmPaperSource /Reel def
/CIP3AdmReelWidth 86 cm def
/CIP3AdmCylinderCircumference 63 cm def
...
CIP3EndSheet
%%CIP3EndOfFile

```

3.2.4 Example: 24 Pages, Portrait

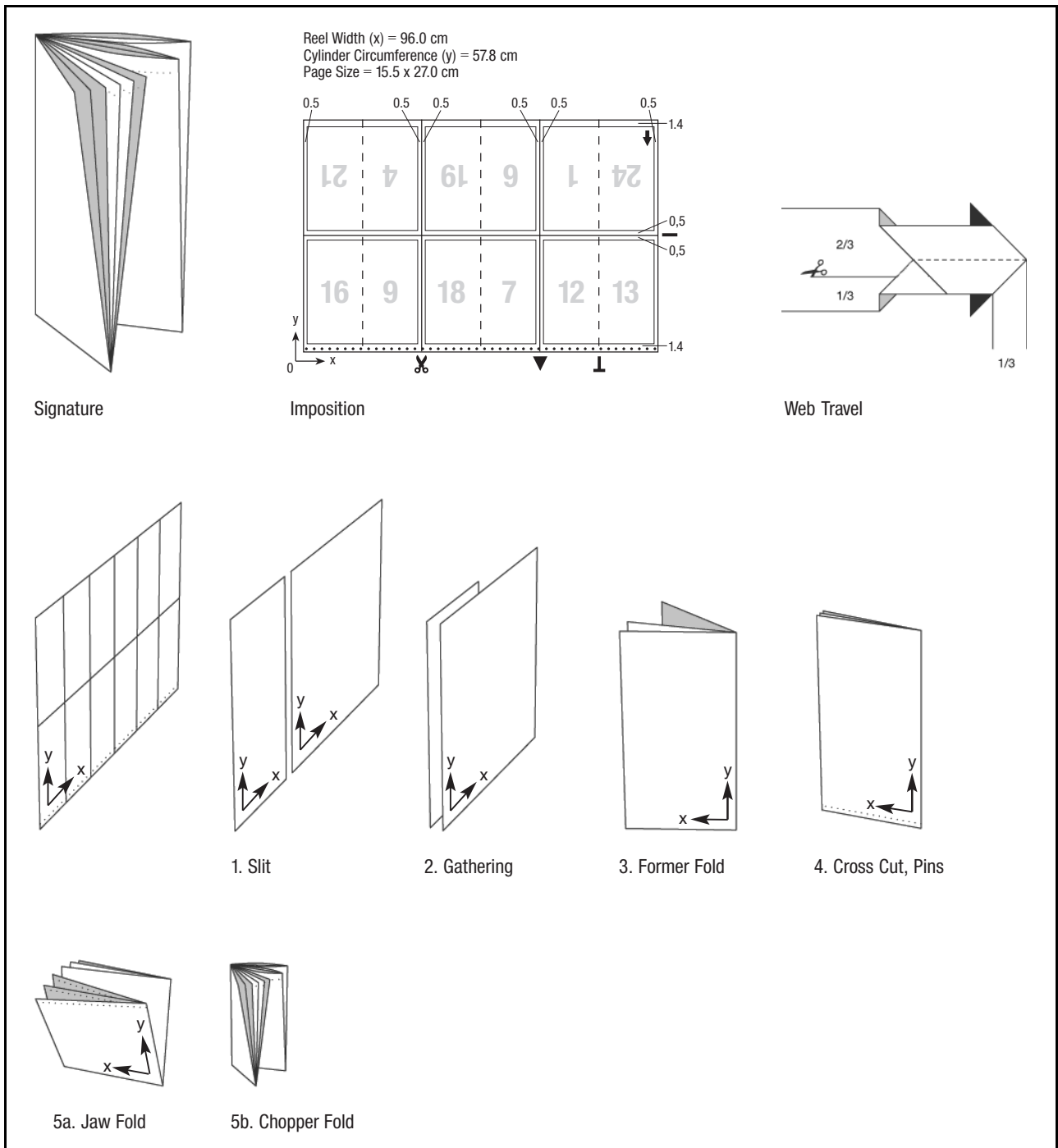

Illustration 3-7: "24 Pages, Portrait" Example

#	Operation	Implementation in CIP3 PPF
1	slitting	A partial product must be defined in the product definition section. The operation is /Dividing . It requires one component, which must be the sheet describing the undivided and flat signature.
2	gathering	A partial product must be defined in the product definition section. The operation is /Gathering . It requires two components, which must be the two ribbons resulting from operation #1.
3	former fold	A partial product must be defined in the product definition section. The operation is /Folding . It requires one component, which must be the gathered ribbons resulting from operation #2.
4	cross cut	A partial product must be defined in the product definition section. The operation is /Dividing . It requires one component, which must be the gathered and folded ribbons resulting from operation #3.
5	jaw fold, chopper fold	A partial product must be defined in the product definition section. The operation is /Folding . It requires one component, which must be the partial product specified in operation #4.

Table 3-11: Implementation of “24 Pages, Portrait” Example

CIP3 PPF Code for “24 Pages, Portrait” Example

```

%!PS-Adobe-3.0
%%CIP3-File Version 3.0
CIP3BeginPPFDirectory
...
CIP3EndPPFDirectory
CIP3BeginProductDefintion
/CIP3Products
[
  <<
    /CIP3ProductName (ribbons)
    /CIP3ProductOperation /Dividing
    /CIP3ProductParams
      <</DividingType /Slitting
        /DividingPositions [ 32 cm ]
        /SubProductNames [ (narrow ribbon) (wide ribbon) ]
      >>
    /CIP3ProductComponents
    [ <</SourceType /Sheet
      /SourceSheet (Web 1)
      /Params <</Orientation [1 0 0 1 0 0] >>
    >>
  ]
>>
<<
  /CIP3ProductName (gathered ribbons)
  /CIP3ProductOperation /Gathering
  /CIP3ProductComponents
  [ <</SourceType /SubProduct
    /SourceProduct (ribbons)
    /SourceSubProduct (narrow ribbon)
    /Params <</Orientation [1 0 0 1 0 0] >>
    >>
    <</SourceType /SubProduct
      /SourceProduct (ribbons)
      /SourceSubProduct (wide ribbon)
      /Params <</Orientation [1 0 0 1 0 0] >>
    >>
  ]
>>
<<
  /CIP3ProductName (former folded)
  /CIP3ProductOperation /Folding
  /CIP3ProductParams
    <</CIP3FoldSheetIn [ 64 cm 57.8 cm ]
      /CIP3FoldProc [ 32 cm /Front /Down Fold ]
    >>
  /CIP3ProductComponents
  [ <</SourceType /PartialProduct
    /SourceProduct (gathered ribbons)
    /Params <</Orientation [1 0 0 1 0 0] >>
    >>
  ]
>>

```

```

<<
  /CIP3ProductName (cross cut)
  /CIP3ProductOperation /Dividing
  /CIP3ProductParams
    <</DividingType /FirstCrossCut
      /DividingPositions [ 57.8 cm ]
    >>
  /CIP3ProductComponents
  [ <</SourceType /PartialProduct
    /SourceProduct (former folded)
    /Params << /Orientation [1 0 0 1 0 0] >>
  >>
  ]
>>
<<
  /CIP3ProductName (24 Pages, Portrait)
  /CIP3ProductOperation /Folding
  /CIP3ProductParams
    <</CIP3FoldSheetIn [ 32 cm 57.8 cm ]
      /CIP3FoldProc [ 28.9 cm /Left /Down Fold
        16 cm /Front /Down Fold ]
    >>
  /CIP3ProductComponents
  [ <</SourceType /PartialProduct
    /SourceProduct (cross cut)
    /Params << /Orientation [1 0 0 1 0 0] >>
  >>
  ]
>>
] def
/CIP3FinalProducts [(24 Pages, Portrait)] def
CIP3EndProductDefinition
...
CIP3BeginSheet
/CIP3AdmSheetName (Web 1)
/CIP3AdmPSExtent [ 96 cm 57.8 cm ] def
/CIP3AdmPaperSource /Reel def
/CIP3AdmReelWidth 96 cm def
/CIP3AdmCylinderCircumference 57.8 cm def
...
CIP3BeginFront
...
CIP3EndFront
CIP3BeginBack
...
CIP3EndBack
CIP3EndSheet
%%CIP3EndOfFile

```

3.2.5 Example: 2 x 4 Pages Broadsheet, Collected

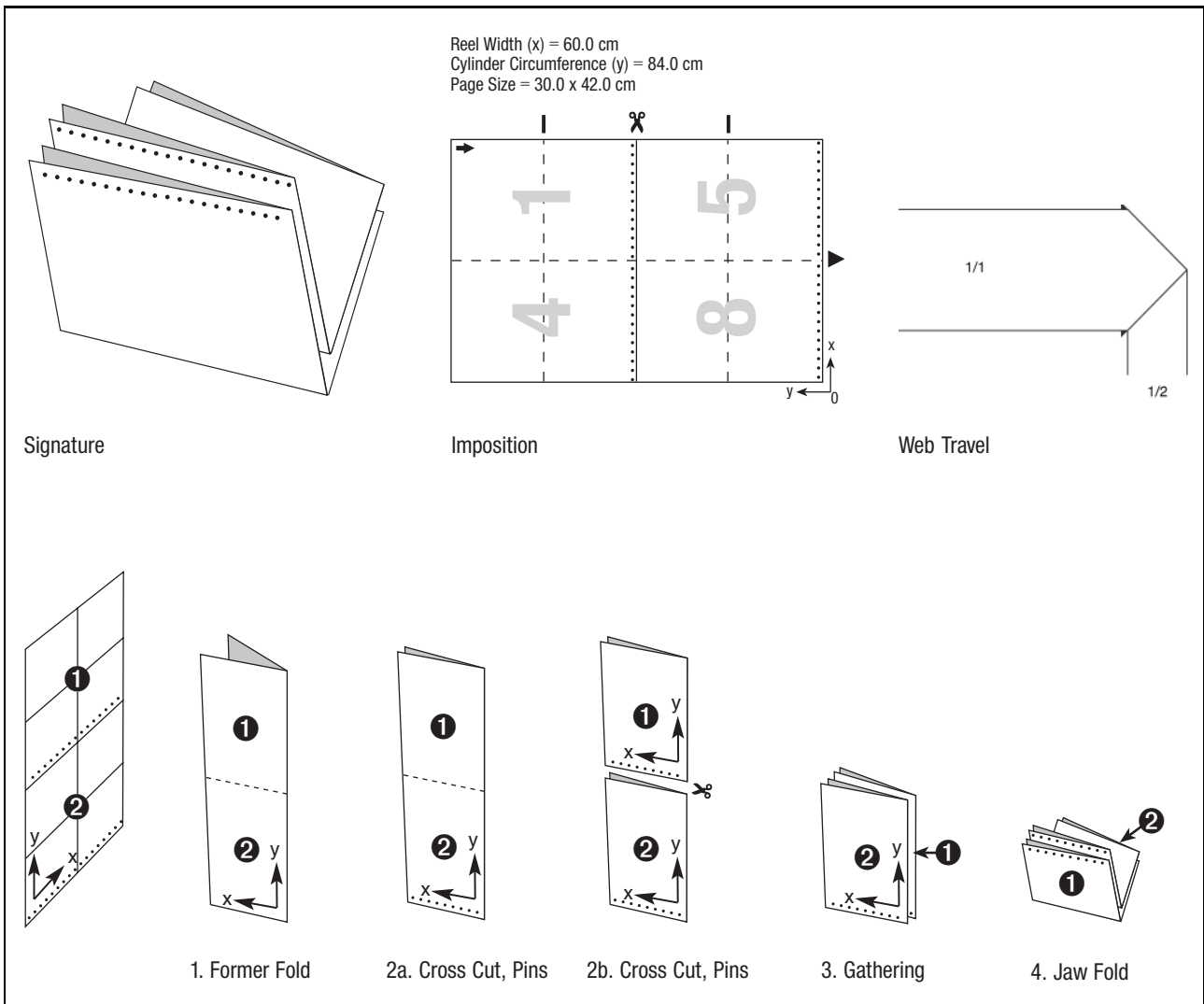

Illustration 3-8: “2 x 4 Pages Broadsheet, Collected” Example

#	Operation	Implementation in CIP3 PPF
1	former fold	A partial product must be defined in the product definition section. The operation is /Folding . It requires one component, which must be the sheet describing the flat signature.
2	cross cuts	A partial product must be defined in the product definition section. The operation is /Dividing . It requires one component, which must be the folded ribbons resulting from operation #1. Two cuts must be defined.
3	gathering	A partial product must be defined in the product definition section. The operation is /Gathering . It requires two components, which must be the two ribbons resulting from operation #2.
4	jaw fold	A partial product must be defined in the product definition section. The operation is /Folding . It requires one component, which must be the partial product specified in operation #3.

Table 3-12: Implementation of “2 x 4 Pages Broadsheet, Collected” Example

CIP3 PPF Code for “2 x 4 Pages Broadsheet, Collected” Example

```

%!PS-Adobe-3.0
%%CIP3-File Version 3.0
CIP3BeginPPFDirectory
...
CIP3EndPPFDirectory
CIP3BeginProductDefintion
/CIP3Products
[
  <<
    /CIP3ProductName (former fold)
    /CIP3ProductOperation /Folding
    /CIP3ProductParams
      <</CIP3FoldSheetIn [ 60 cm 84 cm ]
        /CIP3FoldProc [ 30 cm /Front /Down Fold ]
      >>
    /CIP3ProductComponents
    [ <</SourceType /Sheet
      /SourceSheet (Web 1)
      /Params << /Orientation [1 0 0 1 0 0] >>
    >>
  ]
>>
<<
  /CIP3ProductName (cross cuts)
  /CIP3ProductOperation /Dividing
  /CIP3ProductParams
    <</DividingType /FirstCrossCut
      /DividingPositions [ 42 cm 84 cm ]
      /SubProductNames [(part 2) (part 1)]
    >>
  /CIP3ProductComponents
  [ <</SourceType /PartialProduct
    /SourceProduct (former fold)
    /Params << /Orientation [1 0 0 1 0 0] >>
  >>
  ]
>>
<<
  /CIP3ProductName (gathered parts)
  /CIP3ProductOperation /Gathering
  /CIP3ProductComponents
  [ <</SourceType /SubProduct
    /SourceProduct (cross cuts)
    /SourceSubProduct (part 2)
    /Params << /Orientation [1 0 0 1 0 0] >>
  >>
    <</SourceType /SubProduct
      /SourceProduct (cross cuts)
      /SourceSubProduct (part 1)
      /Params << /Orientation [1 0 0 1 0 0] >>
    >>
  ]
>>

```

```
<<
  /CIP3ProductName (2 x 4 Pages Broadsheet, Collected)
  /CIP3ProductOperation /Folding
  /CIP3ProductParams
    << /CIP3FoldSheetIn [ 30 cm 42 cm ]
      /CIP3FoldProc [ 21 cm /Left /Down Fold ]
    >>
  /CIP3ProductComponents
  [
    << /SourceType /PartialProduct
      /SourceProduct (gathered parts)
      /Params << /Orientation [1 0 0 1 0 0] >>
    >>
  ]
>>
] def
/CIP3FinalProducts [(2 x 4 Pages Broadsheet, Collected)] def
CIP3EndProductDefinition
...
CIP3BeginSheet
/CIP3AdmSheetName (Web 1)
/CIP3AdmPSExtent [ 60 cm 84 cm ] def
/CIP3AdmPaperSource /Reel def
/CIP3AdmReelWidth 60 cm def
/CIP3AdmCylinderCircumference 84 cm def
...
CIP3BeginFront
...
CIP3EndFront
CIP3BeginBack
...
CIP3EndBack
CIP3EndSheet
%%CIP3EndOFFile
```

3.2.6 Example: 2 x 4 Pages Broadsheet, Non-collected

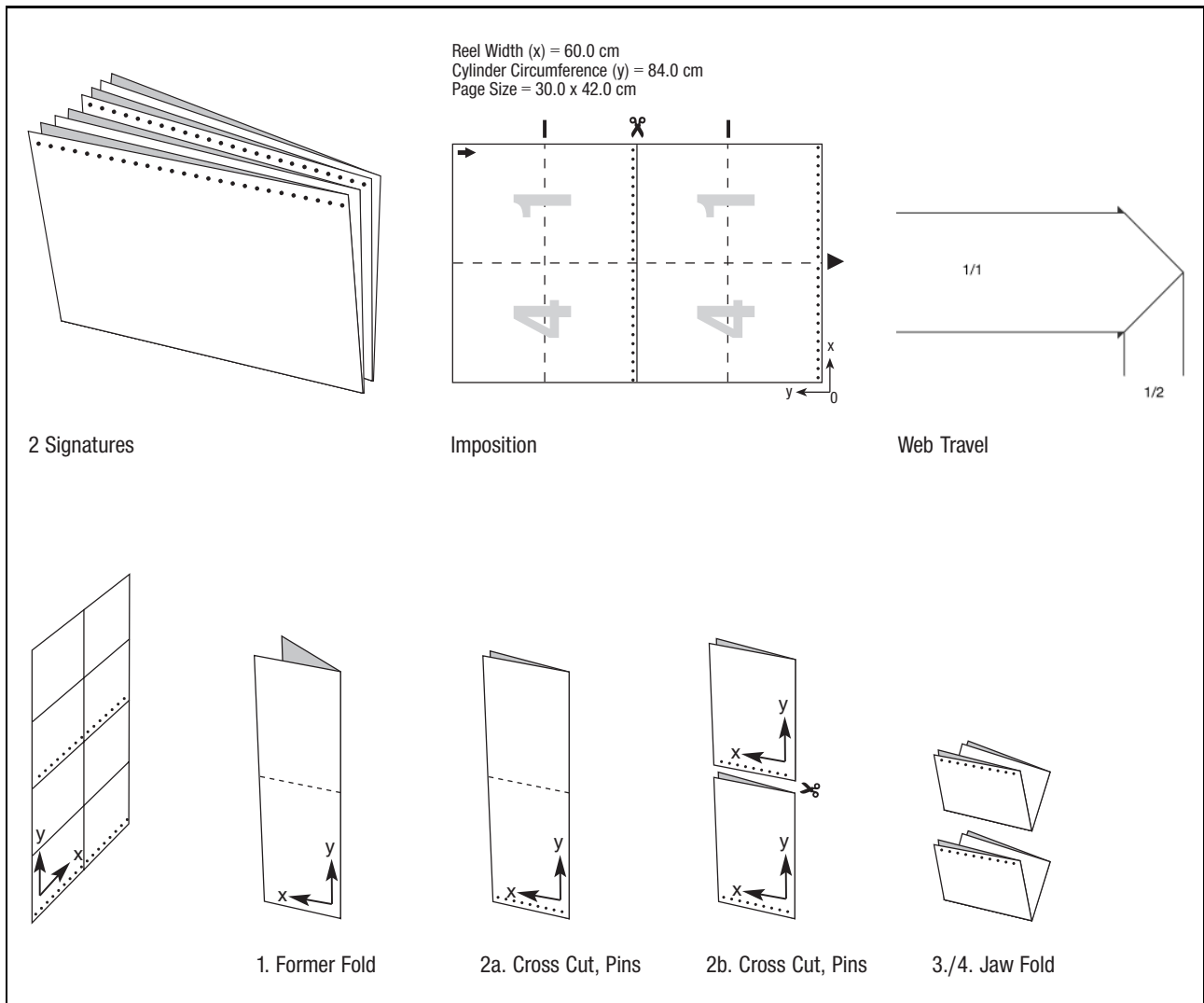

Illustration 3-9: “2 x 4 Pages Broadsheet, Non-collected” Example

#	Operation	Implementation in CIP3 PPF
1	former fold	A partial product must be defined in the product definition section. The operation is /Folding . It requires one component, which must be the sheet describing the flat signature.
2	cross cuts	A partial product must be defined in the product definition section. The operation is /Dividing . It requires one component, which must be the folded ribbons resulting from operation #1. Two cuts must be defined.
3	jaw fold	A partial product must be defined in the product definition section. The operation is /Folding . It requires one component, which must be one of the two partial products specified in operation #2.
4	jaw fold	A partial product must be defined in the product definition section. The operation is /Folding . It requires one component, which must be the other one of the two partial products specified in operation #2.

Table 3-13: Implementation of “2 x 4 Pages Broadsheet, Non-collected” Example

CIP3 PPF Code for “2 x 4 Pages Broadsheet, Non-collected” Example

```

%!PS-Adobe-3.0
%%CIP3-File Version 3.0
CIP3BeginPPFDirectory
...
CIP3EndPPFDirectory
CIP3BeginProductDefintion
/CIP3Products
[
  <<
    /CIP3ProductName (former fold)
    /CIP3ProductOperation /Folding
    /CIP3ProductParams
      <</CIP3FoldSheetIn [ 60 cm 84 cm ]
        /CIP3FoldProc [ 30 cm /Front /Down Fold ]
      >>
    /CIP3ProductComponents
    [ <</SourceType /Sheet
      /SourceSheet (Web 1)
      /Params << /Orientation [1 0 0 1 0 0] >>
    >>
  ]
>>
<<
  /CIP3ProductName (cross cuts)
  /CIP3ProductOperation /Dividing
  /CIP3ProductParams
    <</DividingType /FirstCrossCut
      /DividingPositions [ 42 cm 84 cm ]
      /SubProductNames [(part 2) (part 1)]
    >>
  /CIP3ProductComponents
  [ <</SourceType /PartialProduct
    /SourceProduct (former fold)
    /Params << /Orientation [1 0 0 1 0 0] >>
  >>
  ]
>>
<<
  /CIP3ProductName (2 x 4 Pages Broadsheet, Collected 1)
  /CIP3ProductOperation /Folding
  /CIP3ProductParams
    <</CIP3FoldSheetIn [ 30 cm 42 cm ]
      /CIP3FoldProc [ 21 cm /Left /Down Fold ]
    >>
  /CIP3ProductComponents
  [ <</SourceType /SubProduct
    /SourceProduct (cross cuts)
    /SourceSubProduct (part 1)
    /Params << /Orientation [1 0 0 1 0 0] >>
  >>
  ]
>>

```

```
<<
  /CIP3ProductName (2 x 4 Pages Broadsheet, Collected 2)
  /CIP3ProductOperation /Folding
  /CIP3ProductParams
    << /CIP3FoldSheetIn [ 30 cm 42 cm ]
      /CIP3FoldProc [ 21 cm /Left /Down Fold ]
    >>
  /CIP3ProductComponents
  [
    << /SourceType /SubProduct
      /SourceProduct (cross cuts)
      /SourceSubProduct (part 2)
      /Params << /Orientation [1 0 0 1 0 0] >>
    >>
  ]
>>
] def
/CIP3FinalProducts [ (2 x 4 Pages Broadsheet, Collected 1)
                    (2 x 4 Pages Broadsheet, Collected 2) ] def
CIP3EndProductDefinition
...
CIP3BeginSheet
/CIP3AdmSheetName (Web 1)
/CIP3AdmPSExtent [ 60 cm 84 cm ] def
/CIP3AdmPaperSource /Reel def
/CIP3AdmReelWidth 60 cm def
/CIP3AdmCylinderCircumference 84 cm def
...
CIP3BeginFront
...
CIP3EndFront
CIP3BeginBack
...
CIP3EndBack
CIP3EndSheet
%%CIP3EndOfFile
```

3.2.7 Example: 36 Pages, Portrait

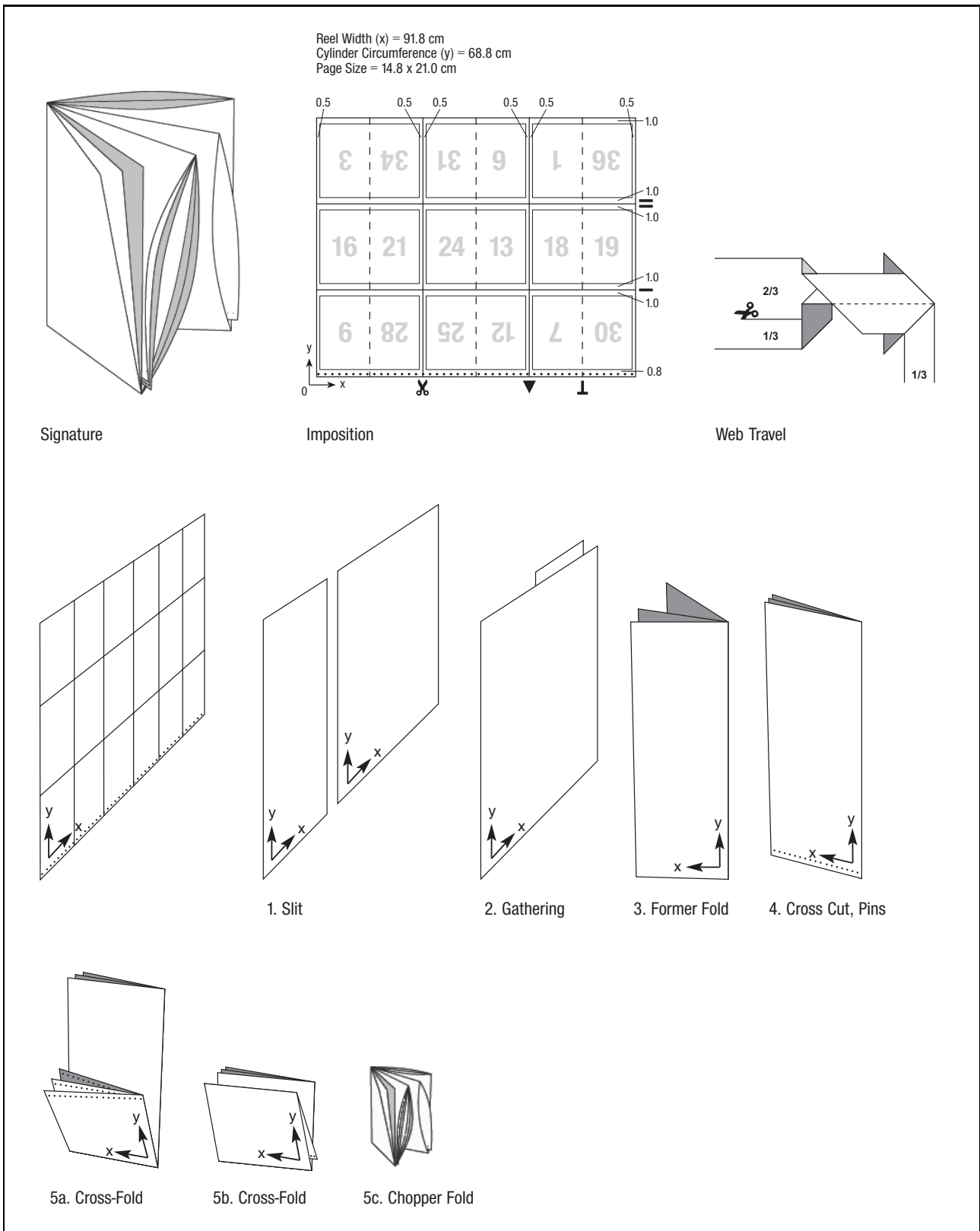

Illustration 3-10: "36 Pages, Portrait" Example

#	Operation	Implementation in CIP3 PPF
1	slitting	A partial product must be defined in the product definition section. The operation is /Dividing . It requires one component, which must be the sheet describing the undivided and flat signature.
2	gathering	A partial product must be defined in the product definition section. The operation is /Gathering . It requires two components, which must be the two ribbons resulting from operation #1.
3	former fold	A partial product must be defined in the product definition section. The operation is /Folding . It requires one component, which must be the gathered ribbons resulting from operation #2.
4	cross cut	A partial product must be defined in the product definition section. The operation is /Dividing . It requires one component, which must be the gathered and folded ribbons resulting from operation #3.
5	2 cross folds, chopper fold	A partial product must be defined in the product definition section. The operation is /Folding . It requires one component, which must be the partial product specified in operation #4.

Table 3-14: Implementation of “36 Pages, Portrait” Example

CIP3 PPF Code for “36 Pages, Portrait” Example

```

%!PS-Adobe-3.0
%%CIP3-File Version 3.0
CIP3BeginPPFDirectory
...
CIP3EndPPFDirectory
CIP3BeginProductDefintion
/CIP3Products
[
  <<
    /CIP3ProductName (ribbons)
    /CIP3ProductOperation /Dividing
    /CIP3ProductParams
      <</DividingType /Slitting
        /DividingPositions [ 30.6 cm ]
        /SubProductNames [ (narrow ribbon) (wide ribbon) ]
      >>
    /CIP3ProductComponents
    [ <</SourceType /Sheet
      /SourceSheet (Web 1)
      /Params <</Orientation [1 0 0 1 0 0] >>
    >>
  ]
>>
<<
  /CIP3ProductName (gathered ribbons)
  /CIP3ProductOperation /Gathering
  /CIP3ProductComponents
  [ <</SourceType /SubProduct
    /SourceProduct (ribbons)
    /SourceSubProduct (narrow ribbon)
    /Params <</Orientation [1 0 0 1 30.6 cm 0] >>
    >>
    <</SourceType /SubProduct
      /SourceProduct (ribbons)
      /SourceSubProduct (wide ribbon)
      /Params <</Orientation [1 0 0 1 0 0] >>
    >>
  ]
>>
<<
  /CIP3ProductName (former folded)
  /CIP3ProductOperation /Folding
  /CIP3ProductParams
    <</CIP3FoldSheetIn [ 61.2 cm 68.8 cm ]
      /CIP3FoldProc [ 30.6 cm /Front /Down Fold ]
    >>
  /CIP3ProductComponents
  [ <</SourceType /PartialProduct
    /SourceProduct (gathered ribbons)
    /Params <</Orientation [1 0 0 1 0 0] >>
    >>
  ]
>>

```

```

<<
  /CIP3ProductName (cross cut)
  /CIP3ProductOperation /Dividing
  /CIP3ProductParams
    <</DividingType /FirstCrossCut
      /DividingPositions [ 68.8 cm ]
    >>
  /CIP3ProductComponents
  [ <</SourceType /PartialProduct
    /SourceProduct (former folded)
    /Params << /Orientation [1 0 0 1 0 0] >>
    >>
  ]
>>
<<
  /CIP3ProductName (36 Pages, Portrait)
  /CIP3ProductOperation /Folding
  /CIP3ProductParams
    <</CIP3FoldSheetIn [ 30.6 cm 68.8 cm ]
      /CIP3FoldProc [ 22.8 cm /Left /Down Fold
        23.0 cm /Left /Down Fold
        15.3 cm /Front /Down Fold ]
    >>
  /CIP3ProductComponents
  [ <<
    /SourceType /PartialProduct
    /SourceProduct (cross cut)
    /Params << /Orientation [1 0 0 1 0 0] >>
    >>
  ]
>>
] def
/CIP3FinalProducts [(36 Pages, Portrait)] def
...
CIP3EndProductDefinition
CIP3BeginSheet
/CIP3AdmSheetName (Web 1)
/CIP3AdmPSExtent [ 91.8 cm 68.8 cm ] def
/CIP3AdmPaperSource /Reel def
/CIP3AdmReelWidth 91.8 cm def
/CIP3AdmCylinderCircumference 68.8 cm def
...
CIP3BeginFront
...
CIP3EndFront
CIP3BeginBack
...
CIP3EndBack
CIP3EndSheet
%%CIP3EndOfFile

```

3.3 Glossary

3.3.1 General Terms

Title	The title is the general name of a publication. It is the highest level of the product definition hierarchy. Examples: “New York Times”, “Le Monde”, “Frankfurter Allgemeine”
Issue	Variation of a title, specific to a particular date or time. Example: “the New York Times from Wednesday, January 26, 2000”
Edition	Variation of a title or an issue, specific to a particular geographic delivery area. Example: “New York Times, East Coast Edition”
Edition Version	Variation of an edition. An edition version may differ from others in price, language, ads, local geographic area, etc. More hierarchical levels named “Edition Version” may be declared. Example: The Zone is an edition version which is specific to a local delivery area.
Final product	The singular output of the postpress operation, which was completely defined prior to the prepress operation. The final product is identified by one path through the hierarchy from “Title” to “Issue”, “Edition”, “Edition Version”, and so on. Corresponds to CIP3FinalProducts which is an attribute defined in version 3.0 of the CIP3 PPF specification.
Logical Section	A part of a product that usually has defined subject content. A logical section is not necessarily identical with a physical section though in many cases it is. The concept of a logical section is not needed for press production.

3.3.2 Press Terms

Press Run	Indicates the press activities that occur while the same set of logical plates is mounted to produce a specific form. The concept of “Press Run” is needed for scheduling.
Form	The identifier assigned to describe the sum of the signatures (of one press run). A form may contain one or more signatures.
Signature	The result of collecting and/or cutting and/or folding one or more ribbons printed in a single press run coming out of one press delivery. One or more ribbons from one or more webs can go into one signature. Results from the operations performed (slitting, gathering, folding). If

	newspaper application, this value is always broadsheet-equivalent. Within a CIP3 PPF file, signatures will be treated as partial products.
Physical Section	A folded part that is easily separated from the product. A physical section consists of one or more four-page sheets which have a common spine fold. A section can also contain a two-page sheet.
Impression	The printed result of one full plate cylinder revolution (or a set of cylinders in color printing) on the front and the back of the web. Equivalent to "Sheet" in sheet-fed printing.
Plate (physical, logical)	A Physical Plate is the actual plate. A Logical Plate is the sum of the plates mounted to one cylinder. Multiple plates per cylinder are typical for newspaper production.
Web	A continuous strip of paper after it has been threaded through the press and before it is slit into ribbons or cross-cut.
Ribbon	Part of the web that enters the folder. In case the web is not slit, the web and the ribbon are identical. Slitting and salvage trim operations on a web can result in one or more ribbons. A ribbon can be further subdivided.
Cut-Off Size	Distance between two cross-cuts which is always an integer division of the circumference of the plate cylinder of the printing unit.
Slit Position	The absolute position of the slit (continuous cut in a longitudinal direction) needed to cut the web into ribbons. This may also be the position of the slit needed for Salvage Trim.
Web Surface	Front or Back. This definition corresponds to the "Sheet Surface" in sheet-fed printing.
Ribbon Order	The order of the ribbons going into the same former. The ribbons are numbered from inside to outside where the inside ribbon is the one in direct contact with the former. Will be described by the Gathering operation in PPF.
Salvage Trim	The paper trimmed from one or both edges of the web(s). This process is used to make the width of the web(s) available match the optimum width required to produce the signature(s) with the correct dimensions.
Fold Type	Description of the fold using the device name used to produce the fold. Usually in the order in which the fold is performed to produce the signature. For example: Former fold, Plow fold, Jaw fold, Chop fold, Drum fold.
Signature destination	The unique identifier of the press delivery the signature is being routed to at the output of the press.

Lap	The difference in the fold dimensions of the resulting signature which is used later in the processing of the signature and may be trimmed off in the final post press product. There are different types of laps. <i>Full</i> is the same lap for all pages in the signature, <i>False</i> is a lap on every other page starting with the inside page, and <i>Modified</i> only requires that the inside page have the lap and then sufficient other pages to ensure the signature will be processed properly in the binding operation.
n Plates to m Fountains	Plate to plate cylinder and fountain mapping. When multiple plates are mounted across the plate cylinder then the part of the fountain, which controls the individual plate, must be identified. This is part of imposition and is implicit when only one plate is possible per printing cylinder. For example, which pages in the product are controlled by which ink keys? In the case of split fountains, more than one color may be printed on the same unit. Thus a separate preview image is needed for each color on the (logical) plate.
Split Fountain	See “n Plates to m Fountains”
Gluing	Glue is automatically applied to the ribbon. This is usually done near where the former fold will be made to hold single page width ribbon in place after the signature has been formed. Gluing is already defined within the Folding operation of the PPF specification.
Selective printing	The process of customizing (e.g. addressing, numbering) each press signature (press output) with printed data. The printing process may be ink-jet or printing wheel (including numbering).
Final Product Page Number	Numerical or alphanumeric page number of the page in the final product. It is usually printed on the page.
Press Page Number	The page number based on the number of pages in a signature referenced to a specific press output. A signature always consists of several press pages.

3.3.3 Postpress Terms

Postpress Job	All postpress operations within a production line to produce a partial or final product, e.g. folding of sheets, gathering, saddle stitching, perfect binding, inserting and trimming of signatures and so on. The postpress job is not specific to web printing. The signature is the interface between web printing and postpress operations.
Signature	<i>see section 3.3.2 “Press Terms” on page 53.</i>
Lap	<i>see section 3.3.2 “Press Terms” on page 53..</i>

Bundle	A number of final or partial products stacked to a bundle and associated physically together and collected in this manner for delivery. A bundle may contain several copies of the same product or several different products (selectively printed or bound).
Insert	<p>Printed product which is placed within another (jacket) printed product. The inserted product can be:</p> <ul style="list-style-type: none">a) a postpress signature (e.g. a newspaper section)b) a partial product (e.g. a saddle stitched product)c) a final product (e.g. a saddle stitched product)d) a sheet (e.g. a reply card)e) a cut block of a sheet (e.g. a reply card)f) any kind of sampleg) a sticker <p>On selective inserting, the configuration of inserting (jacket and insert) is redefined within a production run by a production control system.</p>
Gluing-in	A printed product is glued to a sheet, a signature, or another printed product.
Customizing	<p>Selective printing: The process of customizing (e.g. addressing) signatures, partial products, or final products with printed data. The printing process is typically ink-jet.</p> <p>Label application: Process of applying labels to products. Each label can be unique.</p> <p>Selective inserting and binding: The process of gathering and assembling a customized postpress output per product.</p>

4 Multiple Plates Per Cylinder

In newspaper printing it is common to mount multiple plates to one cylinder. All plates of one cylinder together form a “logical plate”. In practice, very often a single CIP3 PPF file is generated for each physical plate. In this scenario, a system which wants to merge all single CIP3 PPF files of a logical plate into one large CIP3 PPF file needs to know which physical plates belong to which logical plate.

In addition it also needs to know the position and orientation of each physical plate within the logical plate. This information, however, is currently not stored inside a CIP3 PPF file, but must be obtained from a different source.

There are two different types of newspapers: *Broadsheet* and *Tabloid*.

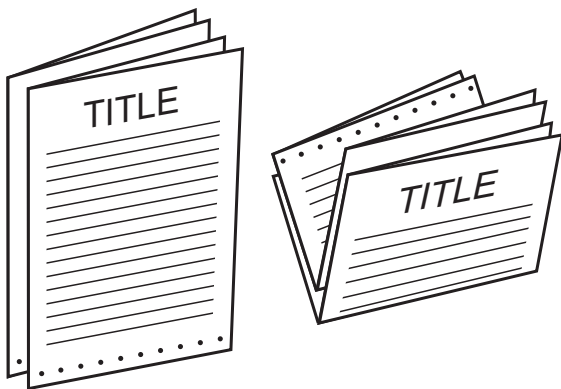

Illustration 4-1: Broadsheet Newspaper

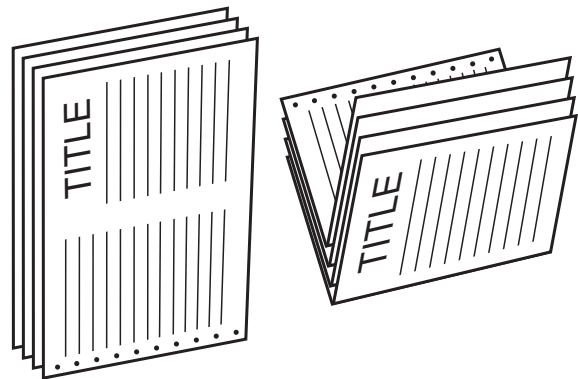

Illustration 4-2: Tabloid Newspaper

When producing a broadsheet newspaper, two types of plates can be used: broadsheet plates and panorama plates. A broadsheet plate can only contain one broadsheet page, while a panorama plate always contains two broadsheet pages. A panorama plate is often used for the inner pages of a newspaper, where one image covers two facing pages.

For the production of a tabloid newspaper, only broadsheet plates are used. In this case, two tabloid pages fit onto one broadsheet plate.

4.1 Specification

Two new attributes are defined for the **Sheet** structure to store the information about which plate is mounted where.

Attribute Name	Type	Necessary	Meaning
CIP3NewspaperPlateType	name	optional	Type of newspaper plate: /Broadsheet or /Panorama . A plate of type /Broadsheet can either contain one broadsheet page or two tabloid pages (see PageType entry of Product Page Dictionary). A plate of type /Panorama always contains two broadsheet pages.
CIP3NewspaperPlateInfo	array of dictionaries	optional	This array contains one Product Page dictionary for each page of the end product which is described by this PPF file.

Table 4-1: New attributes for Sheet structure

Key	Type	Necessary	Meaning
AbsoluteBroadsheetPage	integer	required	Absolute number of broadsheet page.
PageType	name	required	Page type: /Broadsheet or /Tabloid . This entry defines how many newspaper pages (as output at the delivery) fit onto one broadsheet plate. Indirectly, it also defines the final size of the newspaper. /BroadSheet indicates that broadsheet pages are output at the delivery. /Tabloid indicates that tabloid pages are output at the delivery.
PageSection	string	required	Page section: one single character from the range 'A' to 'Z'. <i>This entry is only provided as additional information. It is not used to determine the position of the physical plate within the logical plate.</i>
PageNumber	string	required	Page number within a page section. <i>This entry is only provided as additional information. It is not used to determine the position of the physical plate within the logical plate.</i>

Table 4-2: Product Page dictionary

4.2 Examples

Example 4-1: Mini-newspaper with 4 broadsheet pages

This example shows a small black&white newspaper with one section containing four broadsheet pages. It is produced with three plates: two broadsheet plates on the front side, and one panorama plate on the back side of the web. For each plate a CIP3 PPF file is generated.

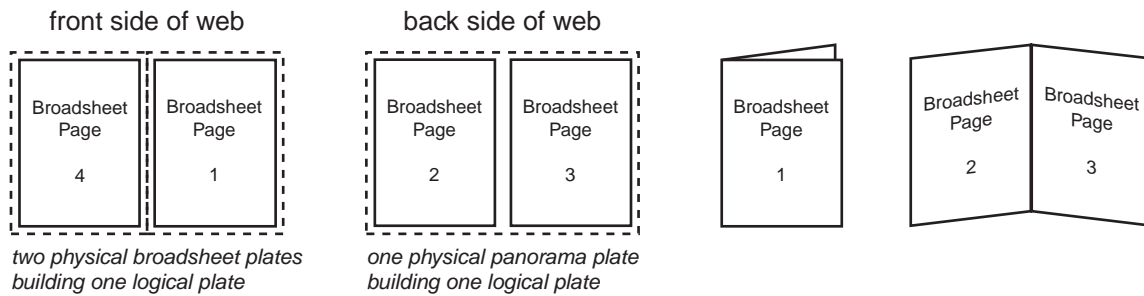

Illustration 4-3: Mini-newspaper with 4 broadsheet pages

CIP3 PPF file for plate containing broadsheet page 1:

```
CIP3BeginSheet
...
/CIP3NewspaperPlateType /Broadsheet def
/CIP3NewspaperPageInfo
 [ << /AbsoluteBroadsheetPage 1
   /PageType /Broadsheet
   /PageSection (A)
   /PageNumber (1)
 >>
 ] def
...
CIP3EndSheet
```

CIP3 PPF file for panorama plate containing broadsheet pages 2 and 3:

```
CIP3BeginSheet
...
/CIP3NewspaperPlateType /Panorama def
/CIP3NewspaperPageInfo
  [ << /AbsoluteBroadsheetPage 2
    /PageType /Broadsheet
    /PageSection (A)
    /PageNumber (2)
  >>
  << /AbsoluteBroadsheetPage 3
    /PageType /Broadsheet
    /PageSection (A)
    /PageNumber (3)
  >>
  ] def
...
CIP3EndSheet
```

CIP3 PPF file for plate containing broadsheet page 4:

```
CIP3BeginSheet
...
/CIP3NewspaperPlateType /Broadsheet def
/CIP3NewspaperPageInfo
  [ << /AbsoluteBroadsheetPage 4
    /PageType /Broadsheet
    /PageSection (A)
    /PageNumber (4)
  >>
  ] def
...
CIP3EndSheet
```

Example 4-2: Mini-newspaper with 8 tabloid pages

This example shows a small black&white newspaper with one section containing four broadsheet pages. It is produced with eight tabloid pages on four plates. Each broadsheet plate contains two tabloid pages. For each plate a CIP3 PPF file is generated.

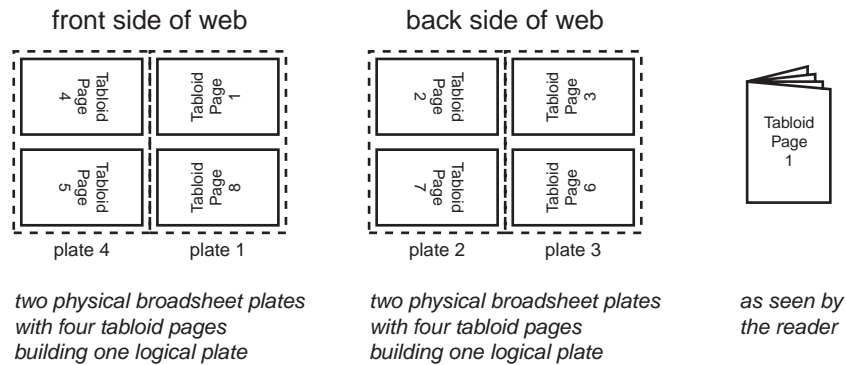
**Illustration 4-4: Mini-newspaper with 8 tabloid pages****CIP3 PPF file for broadsheet plate 1 containing two tabloid pages:**

```

CIP3BeginSheet
...
/CIP3NewspaperPlateType /Broadsheet def
/CIP3NewspaperPageInfo
  [ << /AbsoluteBroadsheetPage 1
    /PageType /Tabloid
    /PageSection (A)
    /PageNumber (8)
  >>
  << /AbsoluteBroadsheetPage 1
    /PageType /Tabloid
    /PageSection (A)
    /PageNumber (1)
  >>
  ] def
...
CIP3EndSheet

```

CIP3 PPF file for broadsheet plate 2 containing two tabloid pages:

```
CIP3BeginSheet
...
/CIP3NewspaperPlateType /Broadsheet def
/CIP3NewspaperPageInfo
  [ << /AbsoluteBroadsheetPage 2
    /PageType /Tabloid
    /PageSection (A)
    /PageNumber (2)
  >>
  << /AbsoluteBroadsheetPage 2
    /PageType /Tabloid
    /PageSection (A)
    /PageNumber (7)
  >>
  ] def
...
CIP3EndSheet
```

CIP3 PPF file for broadsheet plate 3 containing two tabloid pages:

```
CIP3BeginSheet
...
/CIP3NewspaperPlateType /Broadsheet def
/CIP3NewspaperPageInfo
  [ << /AbsoluteBroadsheetPage 3
    /PageType /Tabloid
    /PageSection (A)
    /PageNumber (6)
  >>
  << /AbsoluteBroadsheetPage 3
    /PageType /Tabloid
    /PageSection (A)
    /PageNumber (3)
  >>
  ] def
...
CIP3EndSheet
```

CIP3 PPF file for broadsheet plate 4 containing two tabloid pages:

```
CIP3BeginSheet
...
/CIP3NewspaperPlateType /Broadsheet def
/CIP3NewspaperPageInfo
  [ << /AbsoluteBroadsheetPage 4
    /PageType /Tabloid
    /PageSection (A)
    /PageNumber (4)
  >>
  << /AbsoluteBroadsheetPage 4
    /PageType /Tabloid
    /PageSection (A)
    /PageNumber (5)
  >>
  ] def
...
CIP3EndSheet
```

5 New Attributes

The following attributes are added to the CIP3 PPF Specification. Since they all are optional, compatibility with “standard” CIP3 PPF Version 3.0 files is not affected.

Attribute Name	Type	Necessary	Meaning
CIP3AdmSheetCode	string	optional	Sheet code. In contrast to the CIP3AdmSheetName attribute, which is used by a human to identify a sheet, this attribute is suitable for identification by a computer program (e.g. as an index field within a data base).
CIP3AdmInkColorsCMYK	array of arrays of 4 numbers	optional	Ink color specification in CMYK. The sequence of the ink color specification arrays must match the sequence of the separations as specified by the CIP3AdmSeparationNames attribute. Each of the inner arrays must contain four numbers specifying the CMYK approximation of the respective separation color. The four CMYK values must be given in percent.
CIP3AdmWorkStyle	name	optional	Work style. This attribute defines the relation between the coordinates systems on the front side, and the coordinate systems on the back side of the sheet. Possible values are: /Simplex , /WorkAndBack , /Perfecting , /WorkAndTurn , /WorkAndTumble , and /WorkAndTwist . <i>See chapter 2.2 “Surface-based Coordinate Systems” on page 8 for details about coordinate systems.</i>
CIP3NewspaperPlateType	name	optional	Type of newspaper plate: /Broadsheet or /Panorama . A plate of type /Broadsheet can either contain one broadsheet page or two tabloid pages (see PageType entry of Product Page Dictionary). A plate of type /Panorama always contains two broadsheet pages. <i>See chapter 4 “Multiple Plates Per Cylinder” on page 57 for more information.</i>
CIP3NewspaperPlateInfo	array of dictionaries	optional	This array contains one Product Page dictionary for each page of the end product which is described by this PPF file. <i>See chapter 4 “Multiple Plates Per Cylinder” on page 57 for more information.</i>

Table 5-1: New attributes for Sheet structure

6 Implementation Guidelines

These implementation guidelines are intended as clarifications of some issues arising from the CIP3 Print Production Format (PPF) specification. If there are any conflicts between these notes and the specification, the specification itself takes priority and the comment here should be ignored (please notify CIP3 by mailing to Stefan Daun if you find any such conflicts).

6.1 What should the value of the CIP3AdmJobName key in a PPF file be?

The CIP3 PPF specification defines this field as a PostScript-style string, with no further restrictions. In many cases PPF readers pass the job name to other parts of a control system which have their own limitations on job name length or content. Under these circumstances the reader must apply its own mapping to convert the job name into a suitable format for that system. A reader which fails to read a valid PPF file because the job name is too long for its internal representation, or because it contains characters outside a restricted set does not conform to the CIP3 specification.

The content of the job name field, however, should be useful to the reading application. It is the responsibility of the workflow integrator¹ to ensure that PPF writers create files which contain job names that are appropriate for the workflow and the reader or readers being used. To this end we recommend that both writers and readers be configurable to an extent that allows integrators to connect them in an efficient manner. We also recommend that PPF writers default to using the same content for the job name field in all PPF files created for the same job, and different content for different jobs.

6.2 What should the value of the CIP3AdmSheetName key in a PPF file be?

The CIP3 PPF specification defines this field as a PostScript-style string, with further restrictions on length and characters which may not be used in it. In many cases PPF readers derive information from the string and pass that data to other parts of a control system. If so, the reader must apply its own mapping to convert the data into a suitable format for that system. A reader which fails to read a valid PPF file because the sheet name does not match a specific format does not conform to the CIP3 specification.

The content of the sheet name field should, however, be useful to the reading application. It is the responsibility of the workflow integrator¹ to ensure that PPF writers create files which contain sheet names that are appropriate for the workflow and the reader or readers being used. For instance, if a fully automatic reader needs to be able to derive the sheet number within a signature from each PPF file then that must be encoded in a way which will be understood by that reader. To this end we recommend that both writers and readers be configurable to an extent that allows integrators to connect them in an efficient manner. It may also be appropriate for a reader to reject PPF files which do not contain required information, but this should be done in a controlled manner which gives the operator enough information to understand the cause of the problem and, if possible and appropriate to the product, to enter the missing data manually.

6.3 Size of attributes of type String

Any software receiving CIP3 PPF files must not crash if the length of a string is bigger than it expects. When doing the mapping to a shorter string, at least the first 256 characters of the original string must be taken into account. In other words: String attributes must be distinguished within the first 256 characters.

6.4 Do I need to include CIP3AdmPaperExtent etc. in a PPF file?

The CIP3 PPF specification clearly describes all of the Extent and Transform fields in the administration data section as optional, apart from CIP3AdmPSExtent, which must be present. The default values for missing fields are also clearly described. A PPF file reader which fails to read a valid PPF file because one or more of these optional fields is not included in the file does not conform to the CIP3 specification. It is, however, reasonable for a reader to reject files where the values for extents or transformations (whether included explicitly, or as default values) are inappropriate for the process of which the reader forms a part. If a file is rejected in this way it should be done in a controlled manner which gives the operator enough information to understand the cause of the problem and, if possible and appropriate to the product, to enter the missing data manually.

6.5 CIP3 PPF Version Number

An application writing CIP3 PPF files must write the lowest possible version number into the CIP3 PPF file so that it is compatible to a maximum of reading applications. Otherwise, reading applications may make their own attempt in interpreting the file.

Notes:

- 1) The phrase 'Workflow integrator' is used here to denote the person or organization that is responsible for specification, installation and/or configuration of a workflow involving two or more products using PPF files.

7 Known Errors in CIP3 PPF Version 3.0

The following list of errors refers to version 3.0 of the CIP3 PPF Specification (dated June 2, 1998).

Chapter 3.3.1.3 “Coordinate Systems” on page 31:

The variables **w** and **h** are exchanged by mistake in some of the matrices given in table 3-9. To correct this mistake, variable **w** has to be replaced by variable **h** and vice-versa. This applies to rows 2, 5, 8, and 9. A corrected and improved version of the table is given in this document (see 2-2 “Matrices used to change the orientation” on page 14).

Chapter 3.3.2.7 “End Sheet Gluing” on page 49:

Table 3-21 shows the component specific dictionary for the EndSheetGluing operation (not for the Collecting operation).

Chapter 3.6 “Characteristic Curves for Transfer”, Page 80:

The coordinate P4 given in Table 3-42 is wrong. The right values are: In=0.6, Out =0.525.

Chapter 3.7 “Register Marks”, Page 82:

The word “job” at the end of the second sentence of the second paragraph should be replaced by the word “surface”.

Chapter 3.8 “Color and Ink Control”, page 84:

The **DensityStandard** attribute is of type *Name* (not of type *String*).

Chapter 3.9 “Cutting Data”, Pages 92+93:

The attribute name **CIP3FoldingProcedure** used in the code example on page 92 should be replaced by the attribute name **CIP3BlockFoldingProcedure**. The figure in the code example (especially for the attributes **CIP3BlockSize**, **CIP3BlockElementSize**, **CIP3BlockSubDivision**) do by mistake not match the cutting arrangement as given in illustration 3-27.

Chapter 3.10 “Folding Data”, Page 95:

The last sentence of the first paragraph should read: “Each procedure is stored under a unique name by which it can be referenced in the *CutBlock* structures.”

Appendix A Index of Keywords

A		E	
AbsoluteBroadsheetPage	58	Edition	24, 53
Attributes of type String	66	Edition Version	53
		EditionVersion	24
B		F	
Broadsheet	58, 64	Film coordinate system	8
Broadsheet Newspaper	57	Final product	53
Bundle	56	Final Product Page Number	55
		FinalProduct	24
C		FirstCrossCut	20
Children	24	Fold Type	54
CIP3AdmCreationTime	24	Folding	18
CIP3AdmCylinderCircumference	19	Form	53
CIP3AdmInkColorsCMYK	64		
CIP3AdmJobName	65	G	
CIP3AdmPaperExtent	66	GlueLines	22
CIP3AdmPaperSource	19	Gluing	22, 55
CIP3AdmPSExtent	66	Gluing-in	56
CIP3AdmReelWidth	19		
CIP3AdmSeparationNames	64	I	
CIP3AdmSheetCode	64	Impression	54
CIP3AdmSheetName	64–65	Insert	56
CIP3AdmWorkStyle	10, 64	Issue	24, 53
CIP3BlockFoldingProcedure	67		
CIP3BlockTrf	9	L	
CIP3FinalProducts	23–24, 53	Lap	55
CIP3NewspaperPlateInfo	58, 64	Logical Section	53
CIP3NewspaperPlateType	58, 64		
CIP3ProductHierarchy	23	N	
CIP3Products	23	n Plates to m Fountains	55
Coordinate System	6	Name	24
Block-based	9	NumberOfStitches	20
Surface-based	8		
Used for Folding	13	O	
Used in Product Definition Section	14	Orientation	21–22
CrossCut	20		
Customizing	56	P	
Cut-Off Size	54	PageNumber	58
		PageSection	58
D		PageType	58, 64
Date	24	Panorama	58, 64
DensityStandard	67		
Dividing	18, 20		
DividingPositions	20		
DividingType	20		

Paper coordinate system	8
PartialProduct	20
Perfecting	10–11, 64
Physical Section	54
Plate (physical, logical)	54
Plate coordinate system	8
Postpress Job	55
PostScript coordinate system	8
Press coordinate system	8
Press Page Number	55
Press Run	53
Product Page dictionary	58

R

Relation Between Coordinate Systems .	9
Ribbon	54
Ribbon Order	54
Rotation	6

S

Salvage Trim	54
Selective printing	55
Signature	53, 55
Signature destination	54
Simplex	10–11, 64
Slit Position	54
Slitting	20
SourceProduct	20

SourceSubProduct	20
SourceType	20
Split Fountain	55
StitchPositions	20
SubProduct	20
SubProductNames	20

T

Tabloid	58
Tabloid Newspaper	57
Title	24, 53
Transformations	6
Translation	6
Type	24

V

Version Number	66
Volume	24

W

Web	54
Web Surface	54
WorkAndBack	10–11, 64
WorkAndTumble	10–11, 64
WorkAndTurn	10–11, 64
WorkAndTwist	10–11, 64